

MASSIVE LANGUAGE DIAGRAM

# ARCHITEKTUR INSPIRIERT DURCH DIE SCHMIEDEKUNST

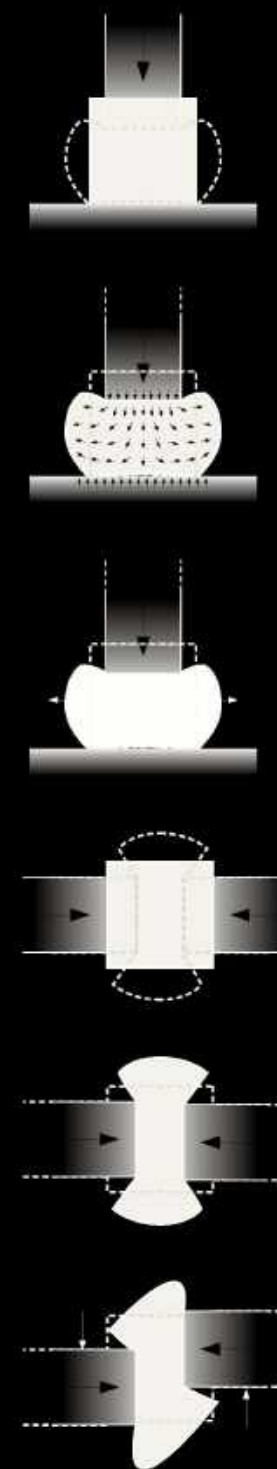

**1 - ARCHITEKTUR UND SCHMIEDEKUNST**

**2 - ARCHITEKTUR INSPIRIERT DURCH DIE SCHMIEDEKUNST**

**3 - ZEITGEMÄSSE UND ZUKUNFTSARCHITEKTUR**

**ARCHITEKTUR  
UND  
SCHMIEDEKUNST**

**ANWENDUNG HISTORISCH**































Nr. 47

11  
Eisenstraße

LEHRWEGE  
DAS KRANKENHAUS  
DER SCHMIEDSCHAF

Informational plaque with text and a logo.





**ANWENDUNG ZEITGEMÄSS**













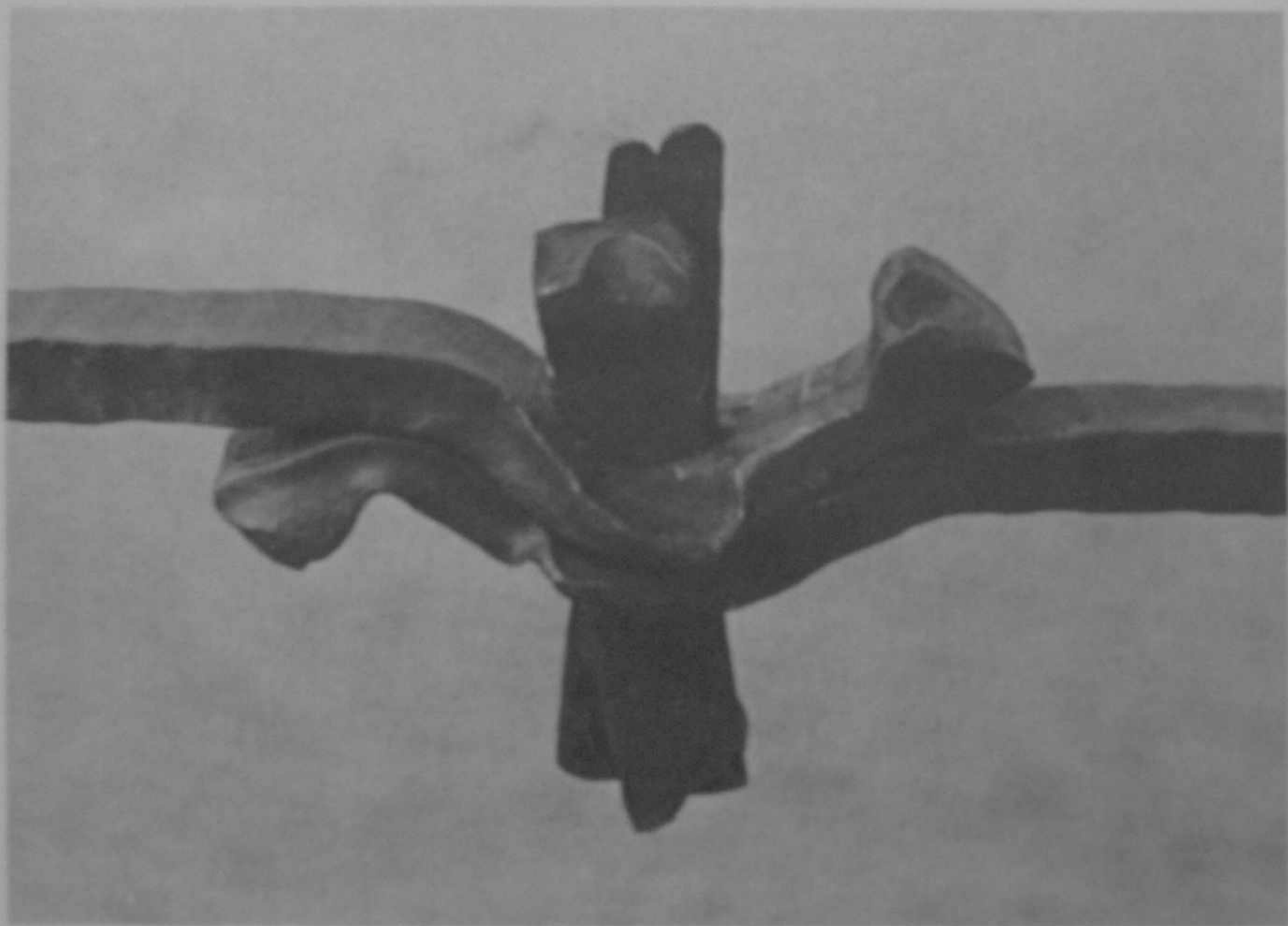



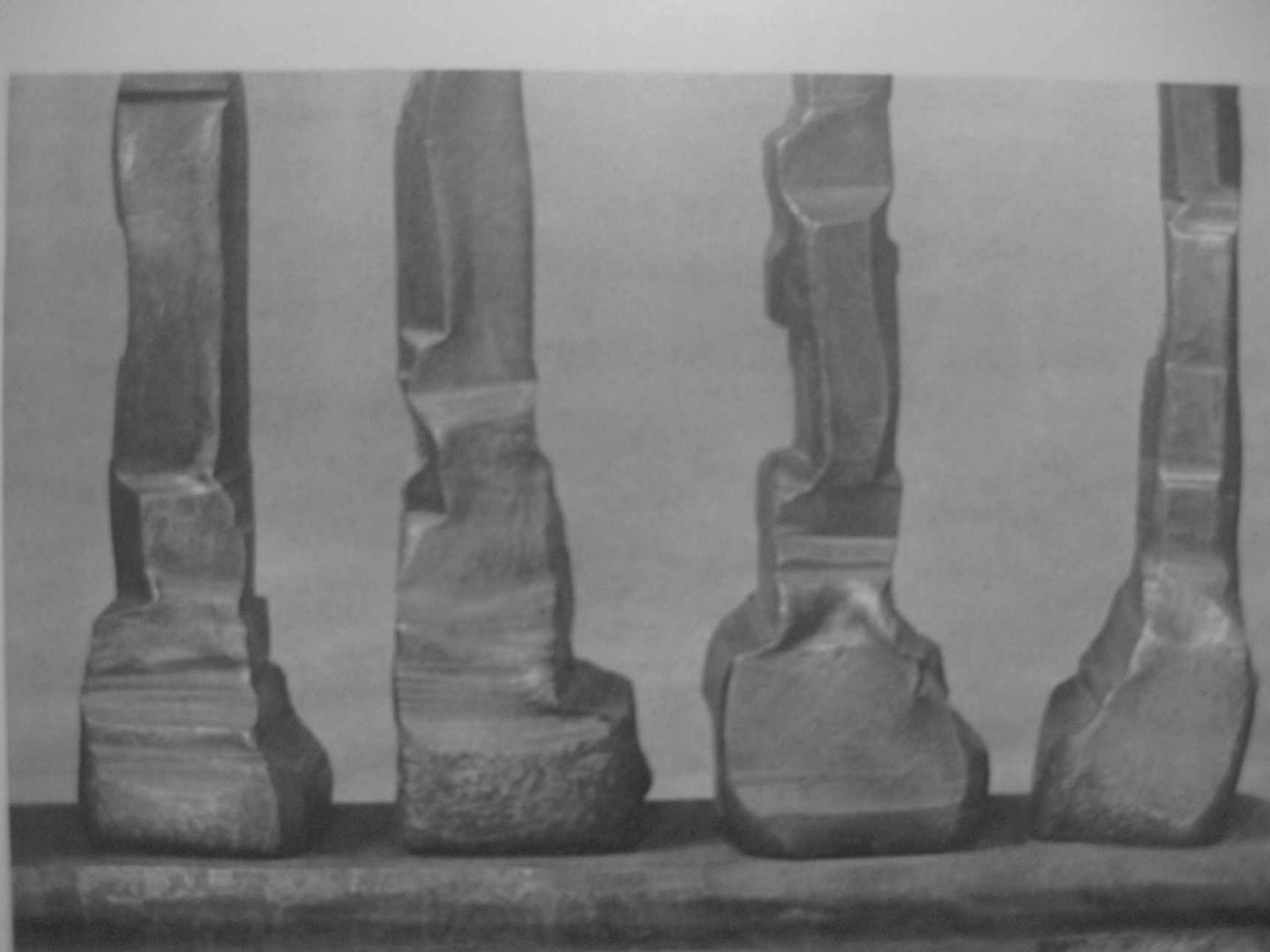



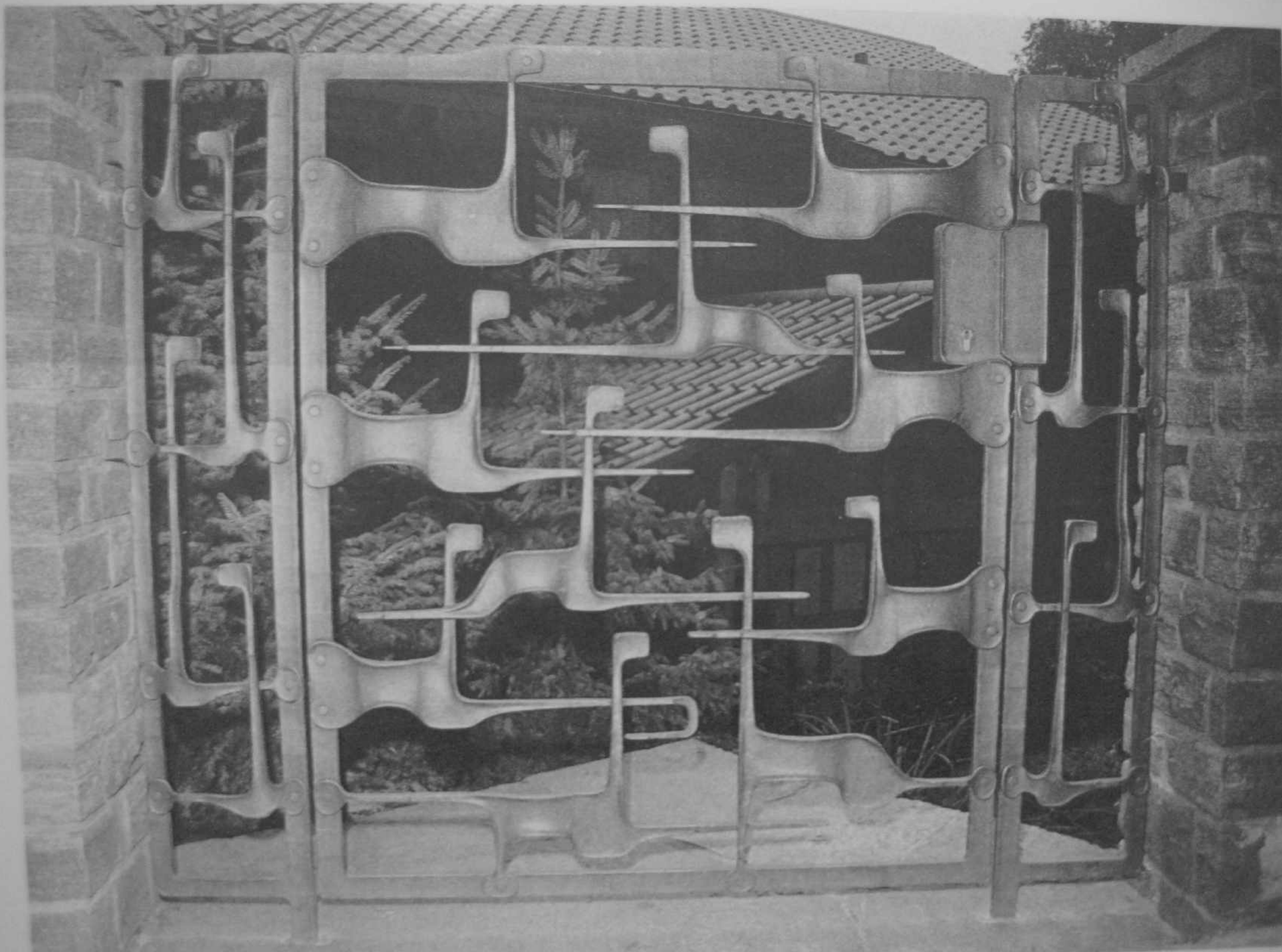

















**KESSELHAUS**

KOLBERMOOR







ybbstiz







Small white informational plaque on the stone wall.





IN OMNIBUS MONTE FIUANT ABSTE













Ausfahrt  
freihalten





















**ARCHITEKTUR INSPIRIERT  
DURCH DIE SCHMIEDEKUNST**



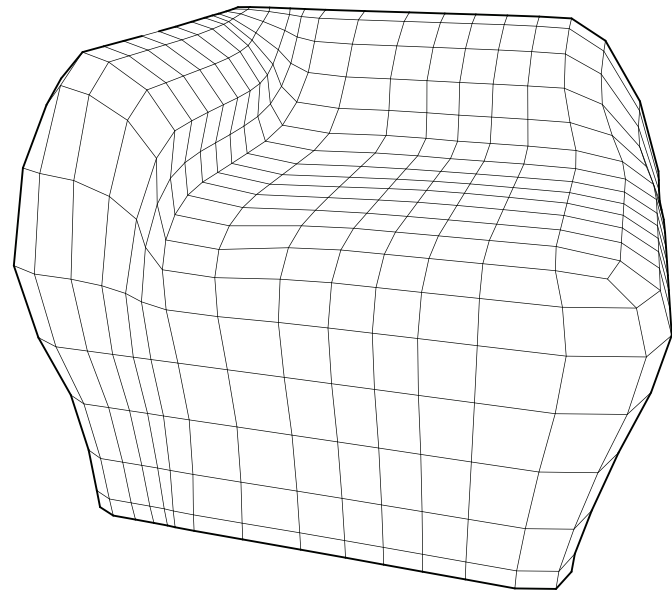

**PERSPECTIVE**

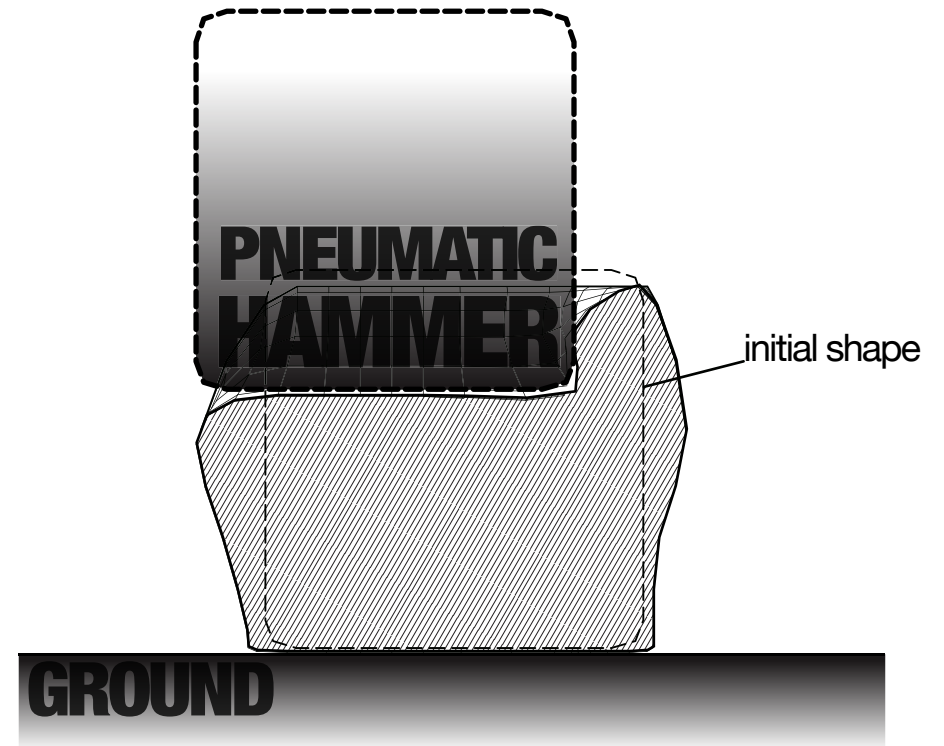

**SECTION**

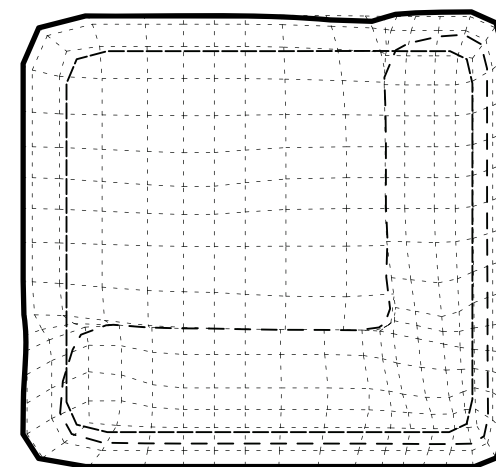

**PLAN**

**INTERIOR PERSPECTIVES**

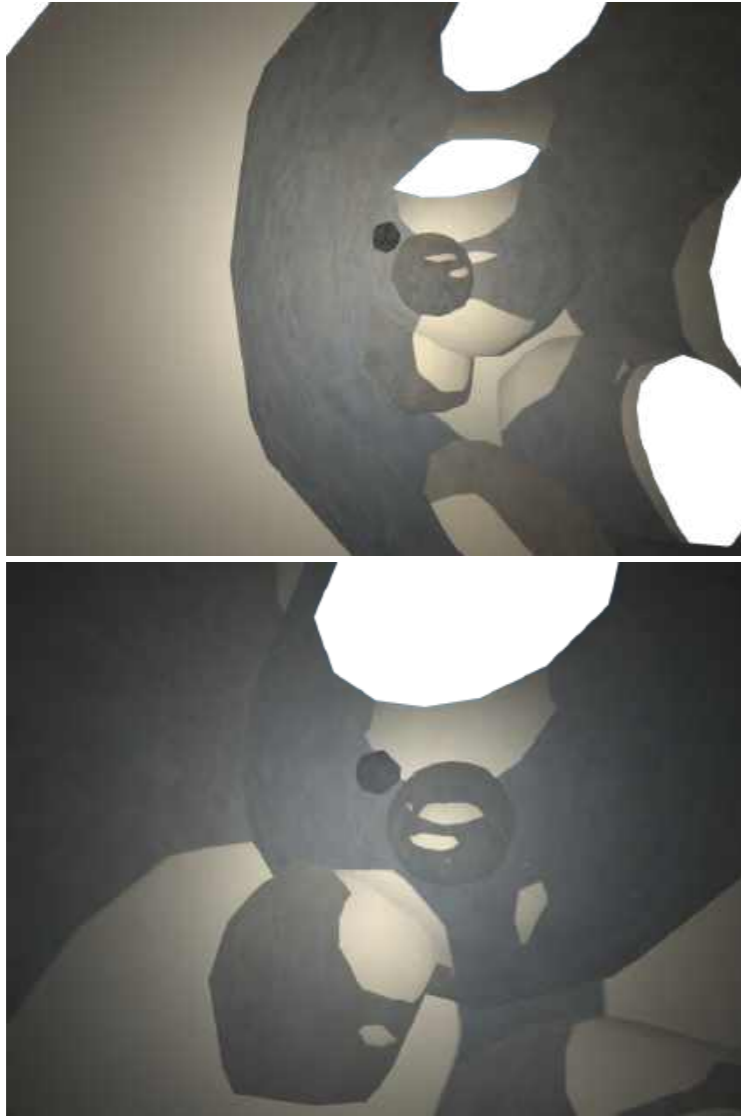

**REFERENCE IMAGE**



**DIAGRAMS void strategy**

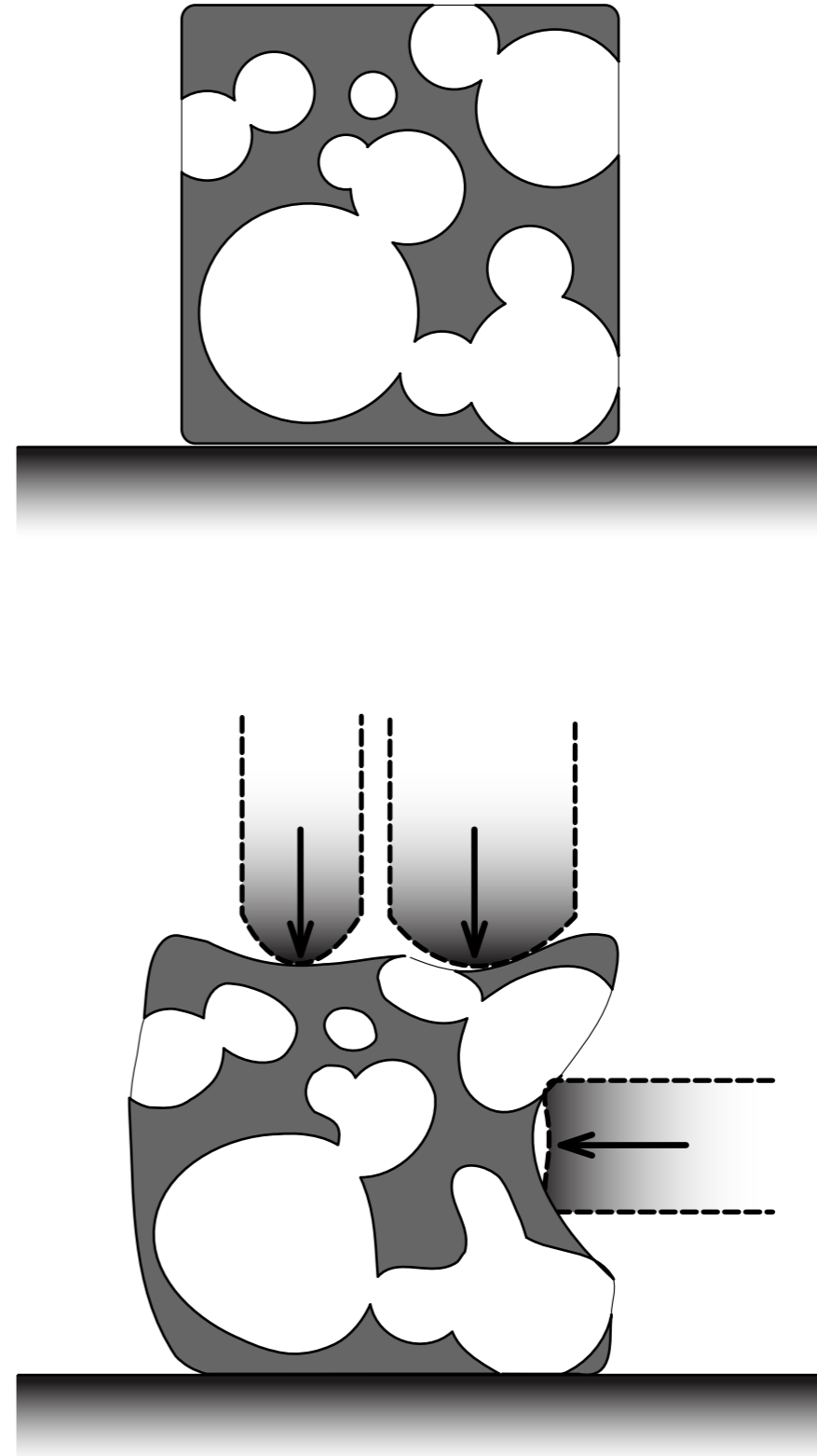



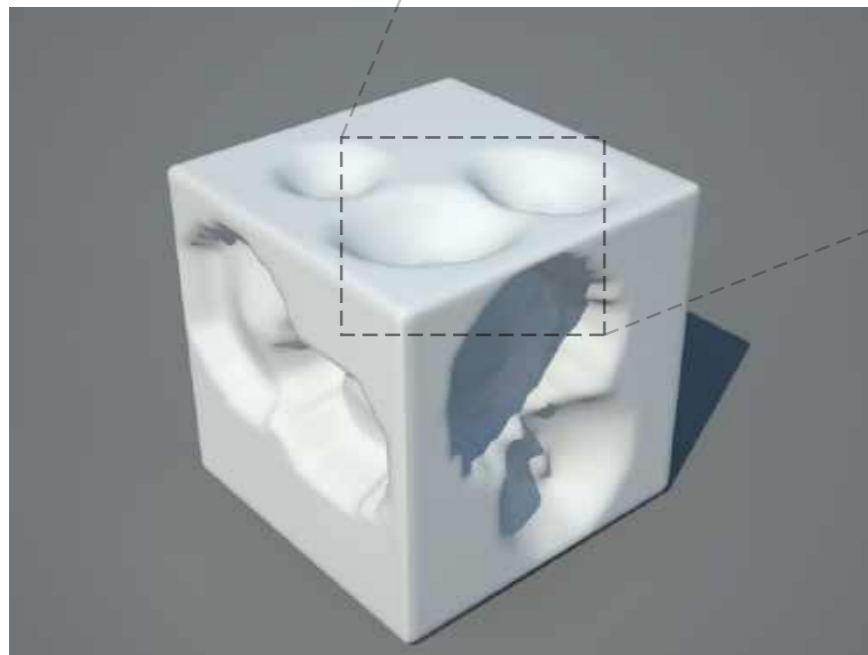
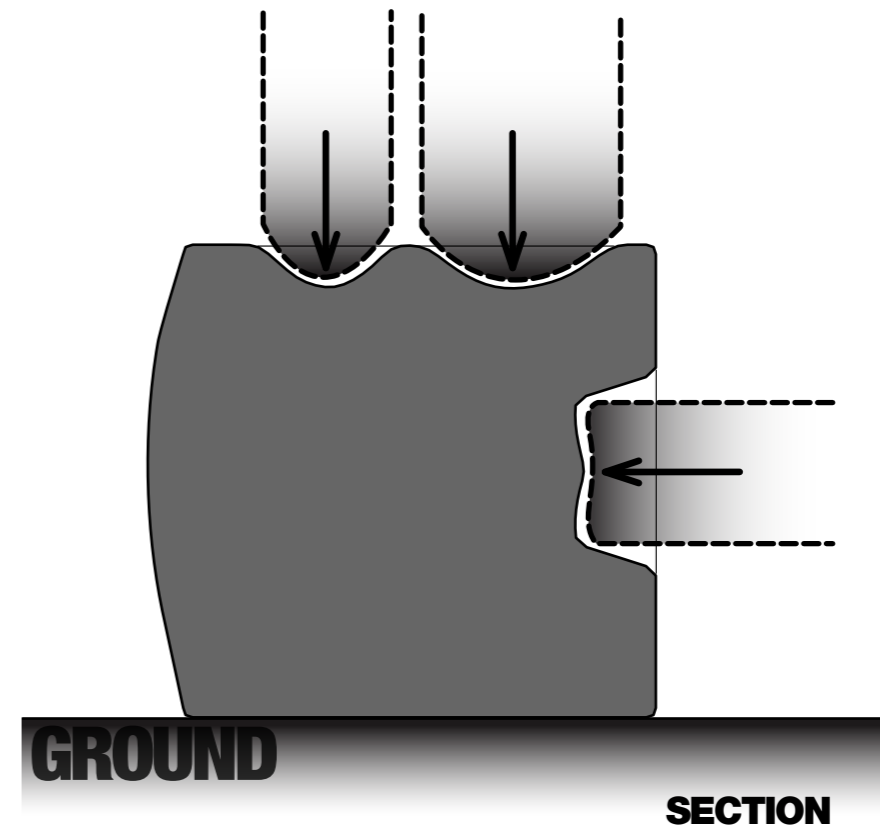
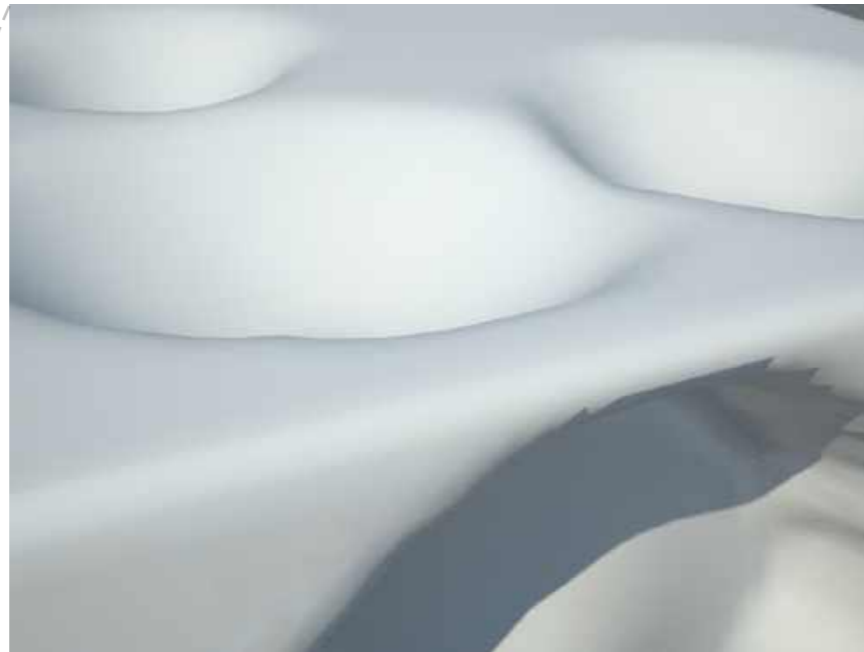

**PERSPECTIVES**

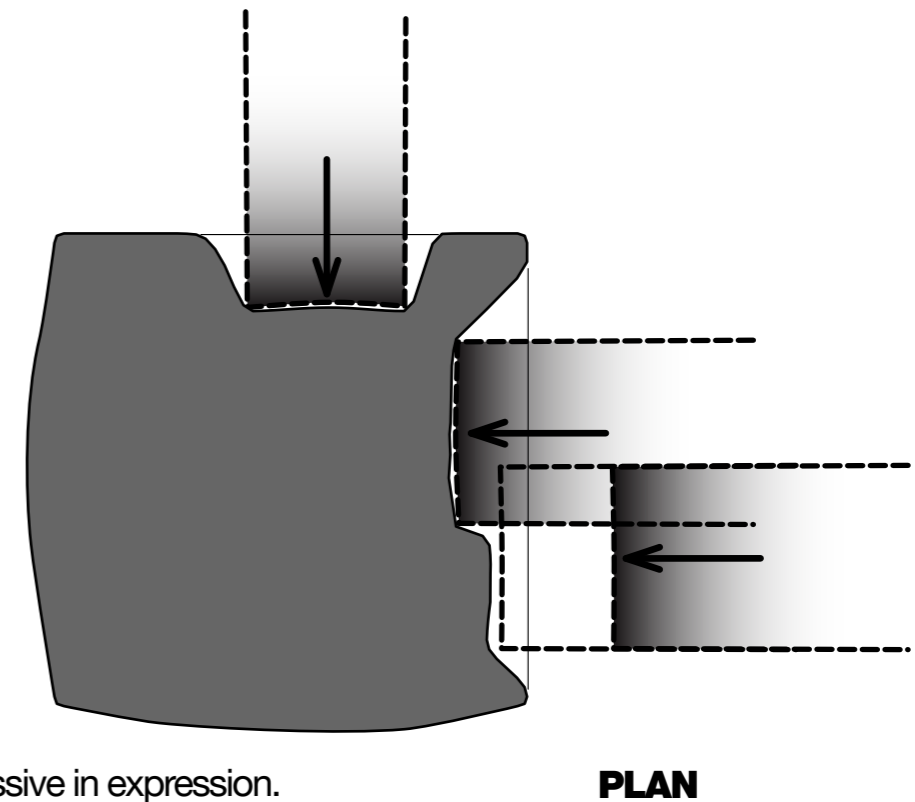

statement:

MASS = INERTIAL

my mass language should be translated by punching bumps into an inertial material.

as mass physically is inertial, mechanically deformed iron (p.e.) feels massive -> the architecture is massive in expression.

the mass effect is realized as punched geometry.

**DIAGRAMS**

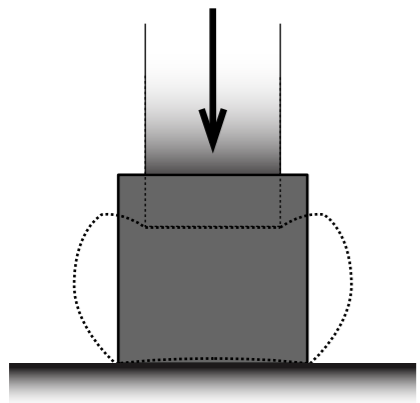

STATE 1:  
an inertial mass geometry (p.e. steel block)  
is being deformed by an external force.

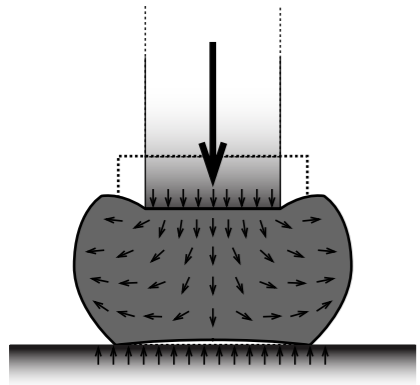

STATE 2:  
the mechanical deformation on the inertial mass  
guides internal forces depending on:  
- initial mass shape  
- value, position and direction of external force & counterforce  
- inertial values of material  
- homogeneity/heterogeneity  
- ...

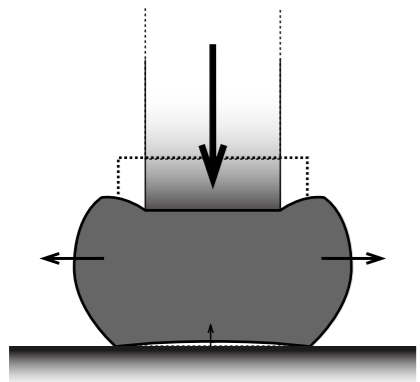

STATE 3:  
the particles or atoms of the mass have been mixed up and moved.  
mass and volume are still the same as the initial volume.

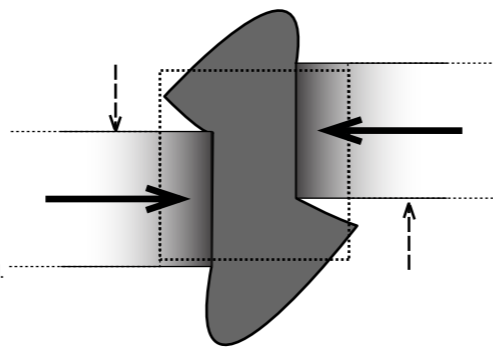
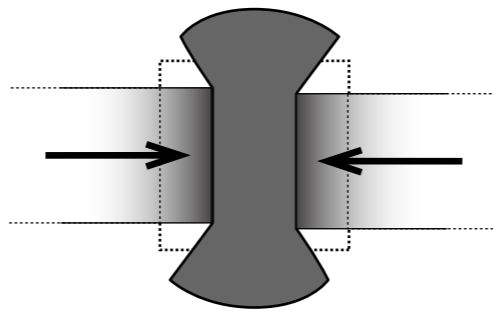
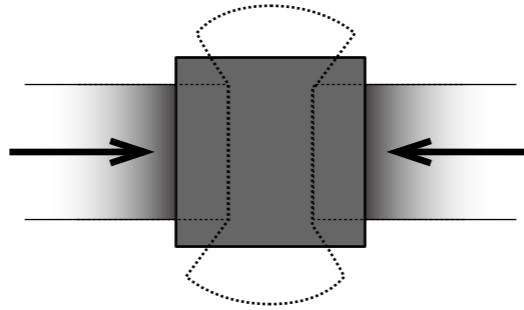

**REFERENCE IMAGES** blacksmith artwork by **Christine Habermann v. Hoch**



iron blocks deformed by external force  
size about 40x40mm

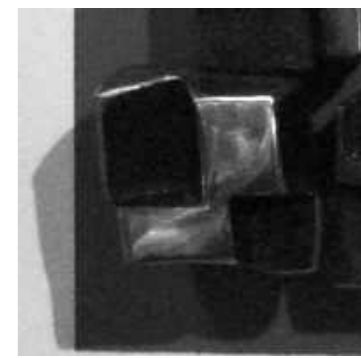



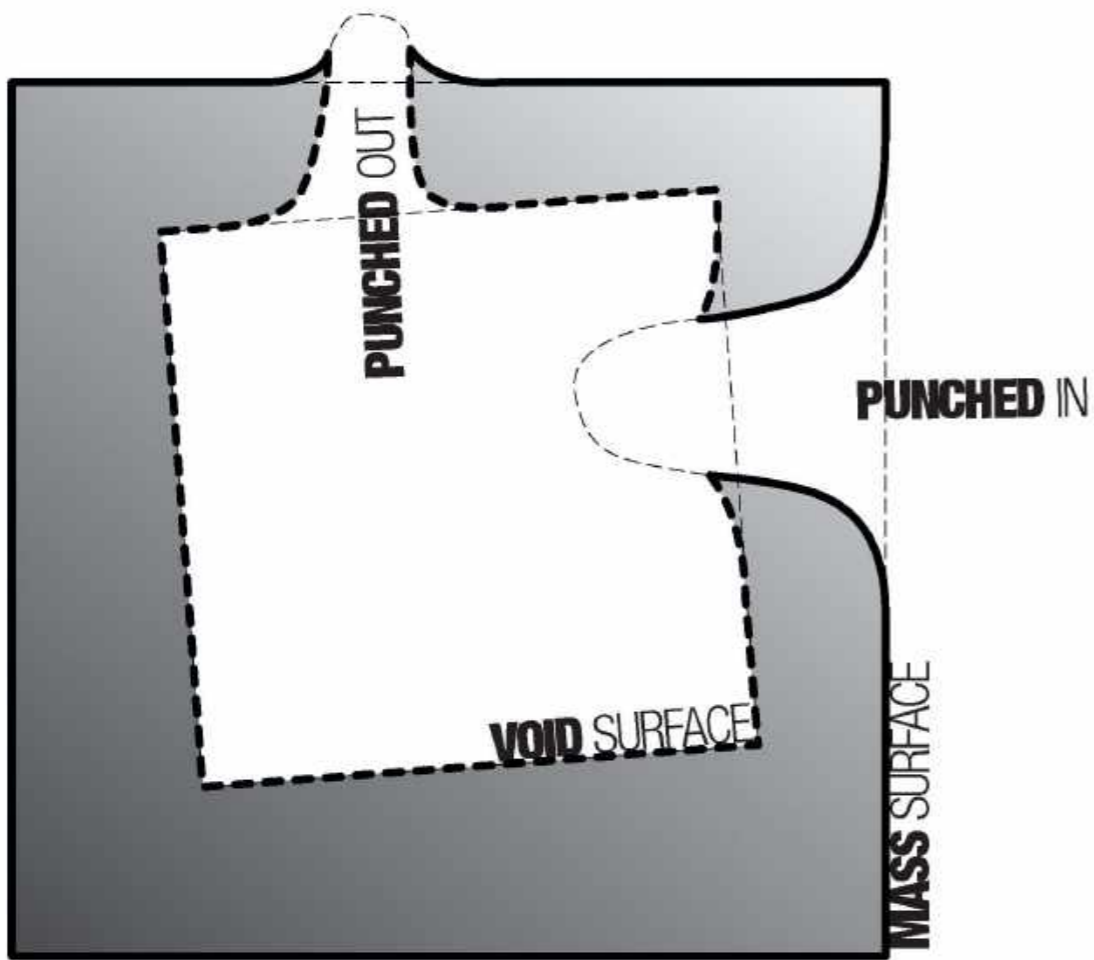

**MASSIVE LANGUAGE** DIAGRAM

**STATEMENT**

MASS = INERTIAL

my mass language should be translated by punching bumps into an inertial material.

punching happens from outside as well as from the inside. so the intersection between mass and void surface results as aperture.

as mass physically is inertial, mechanically deformed iron (p.e.) feels massive -> the architecture is massive in expression.

the mass effect is realized as punched geometry.



JOSEPH STUDIO LYNN WS09  
**MASSIVE** EFFECT

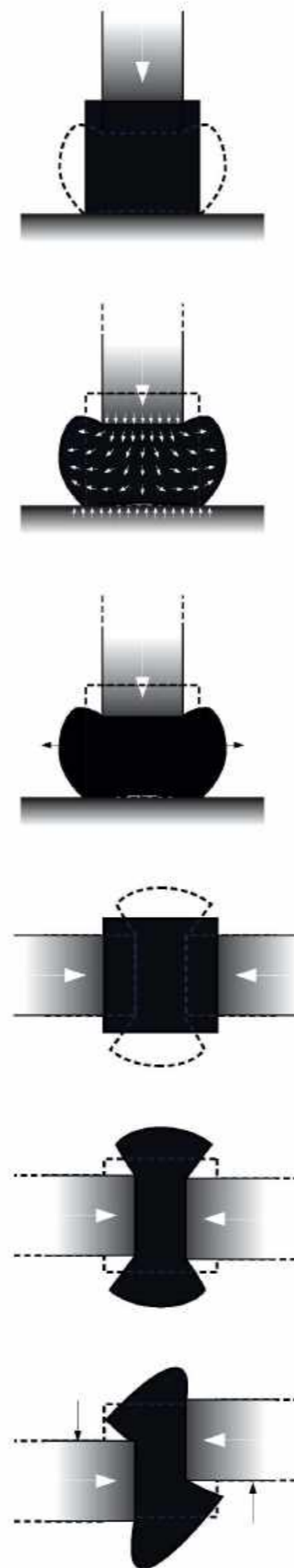

**MASSIVE LANGUAGE** DIAGRAMS



**REFERENCE** IMAGES

blacksmith artwork by **Christine Habermann v. Hoch**



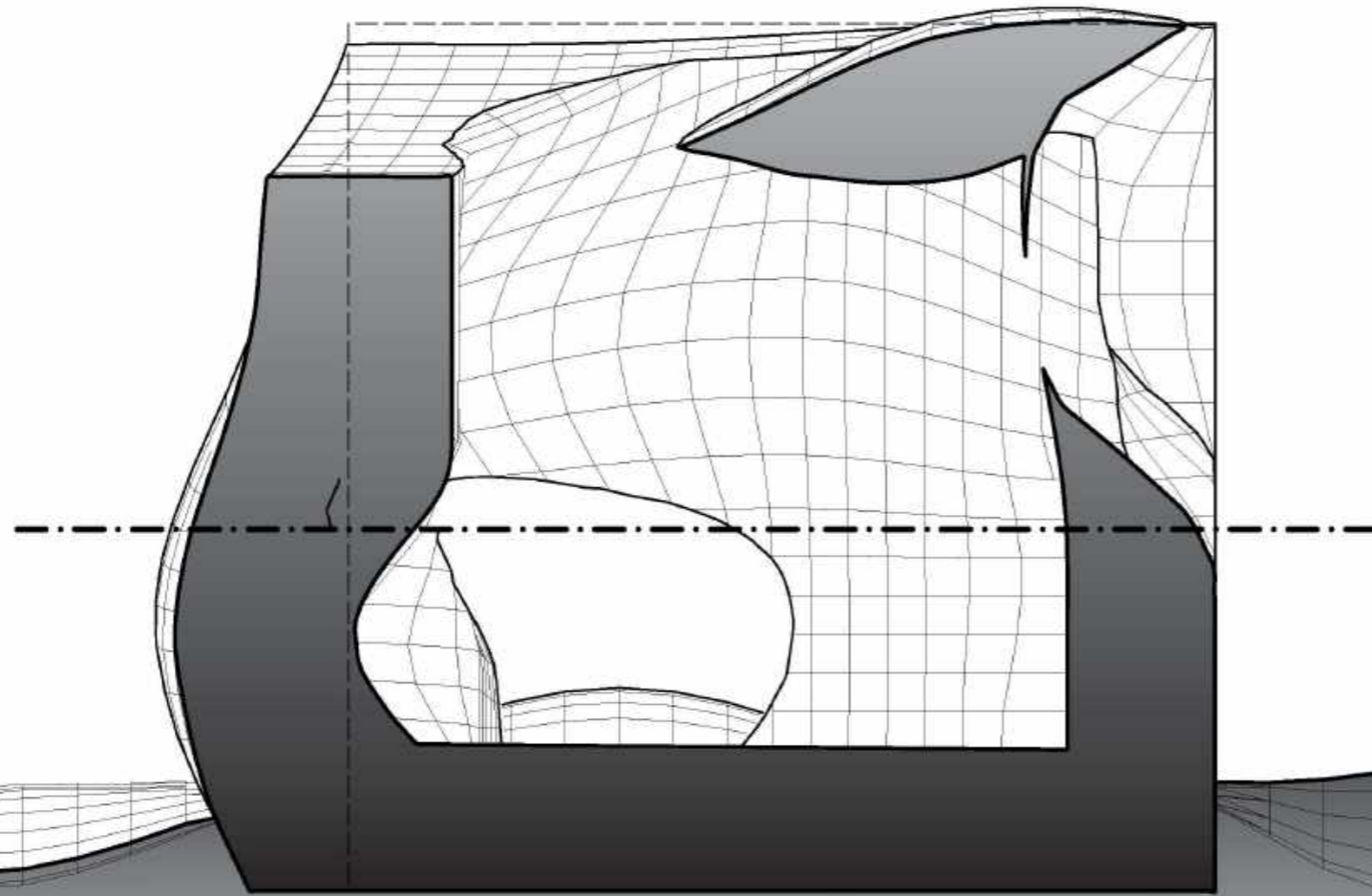

SECTION X

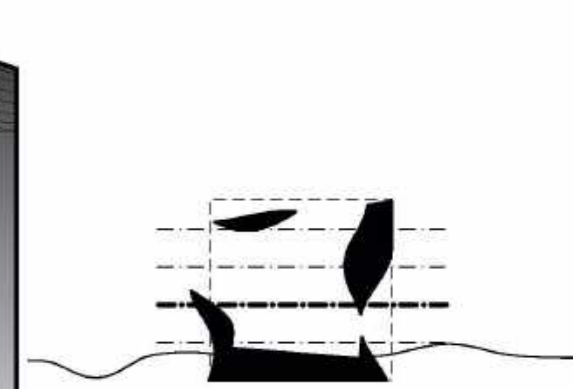
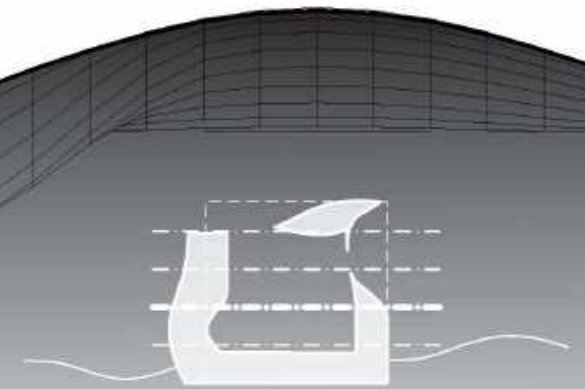
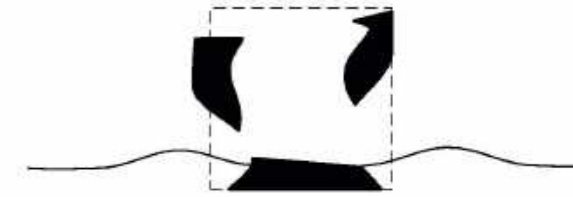
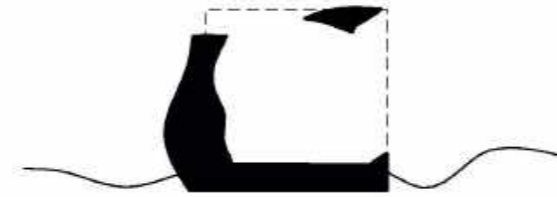
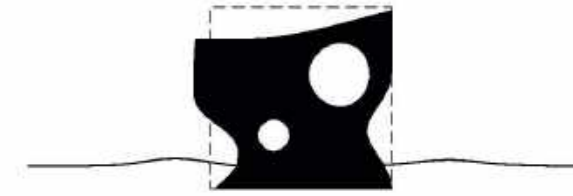

JOSEPH STUDIO LYNN WS09  
**MASSIVE** EFFECT

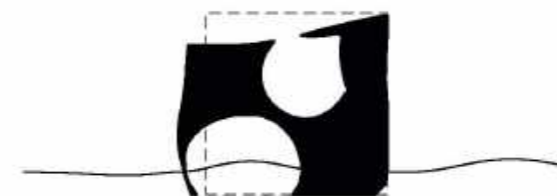

SECTIONSEQUENCE X

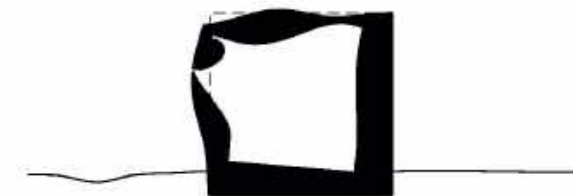

SECTIONSEQUENCE Y



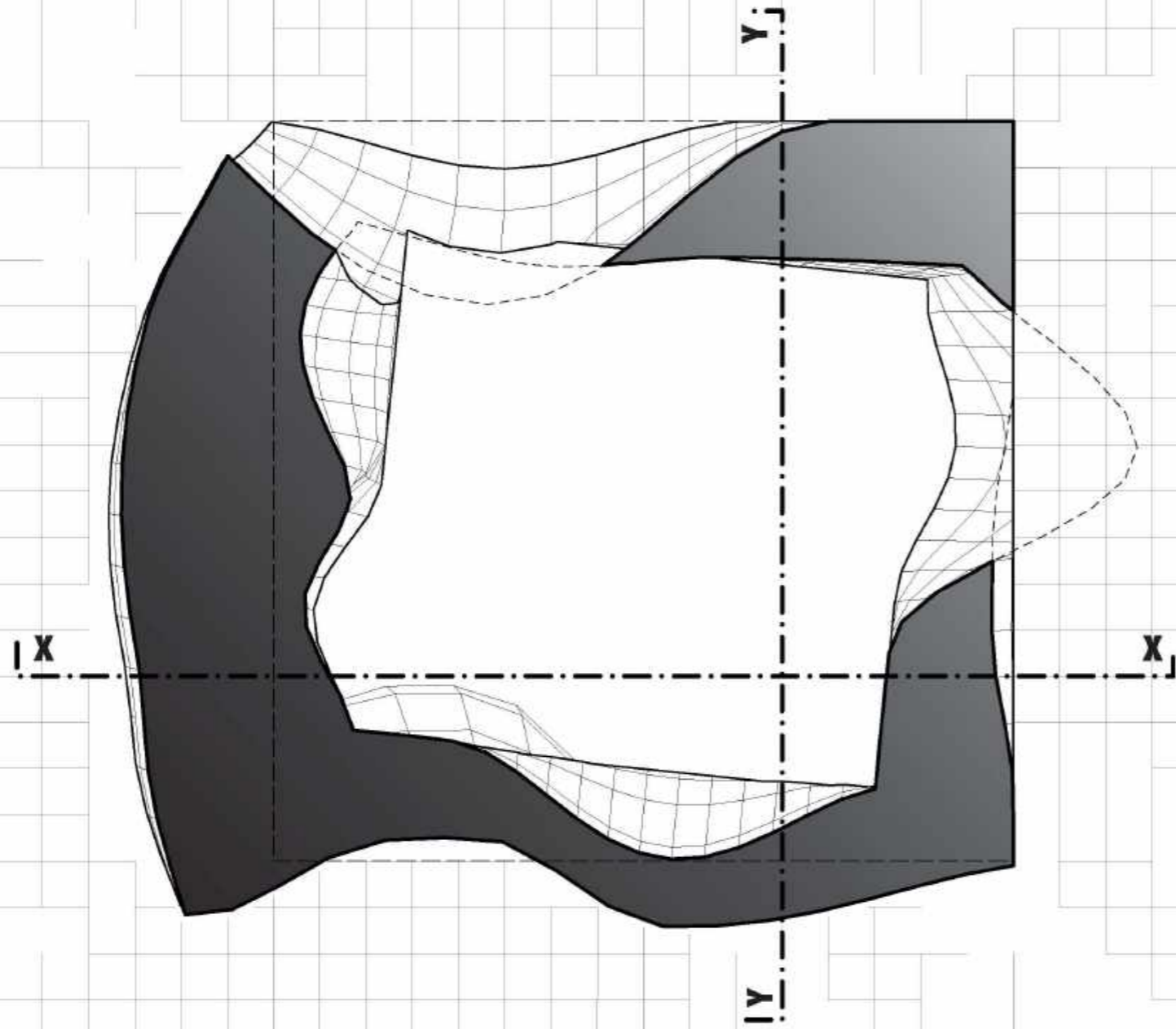

PLAN 1:2

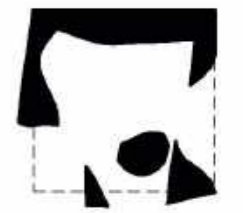
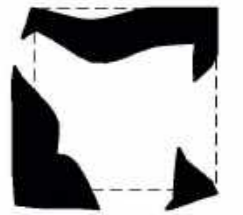
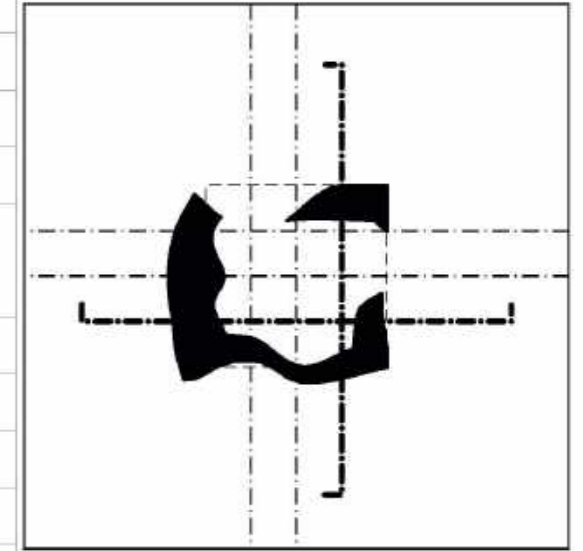
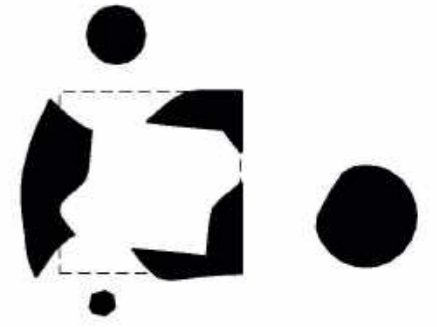

PLANSEQUENCE



JOSEPH STUDIO LYNN WS09  
**MASSIVE** EFFECT



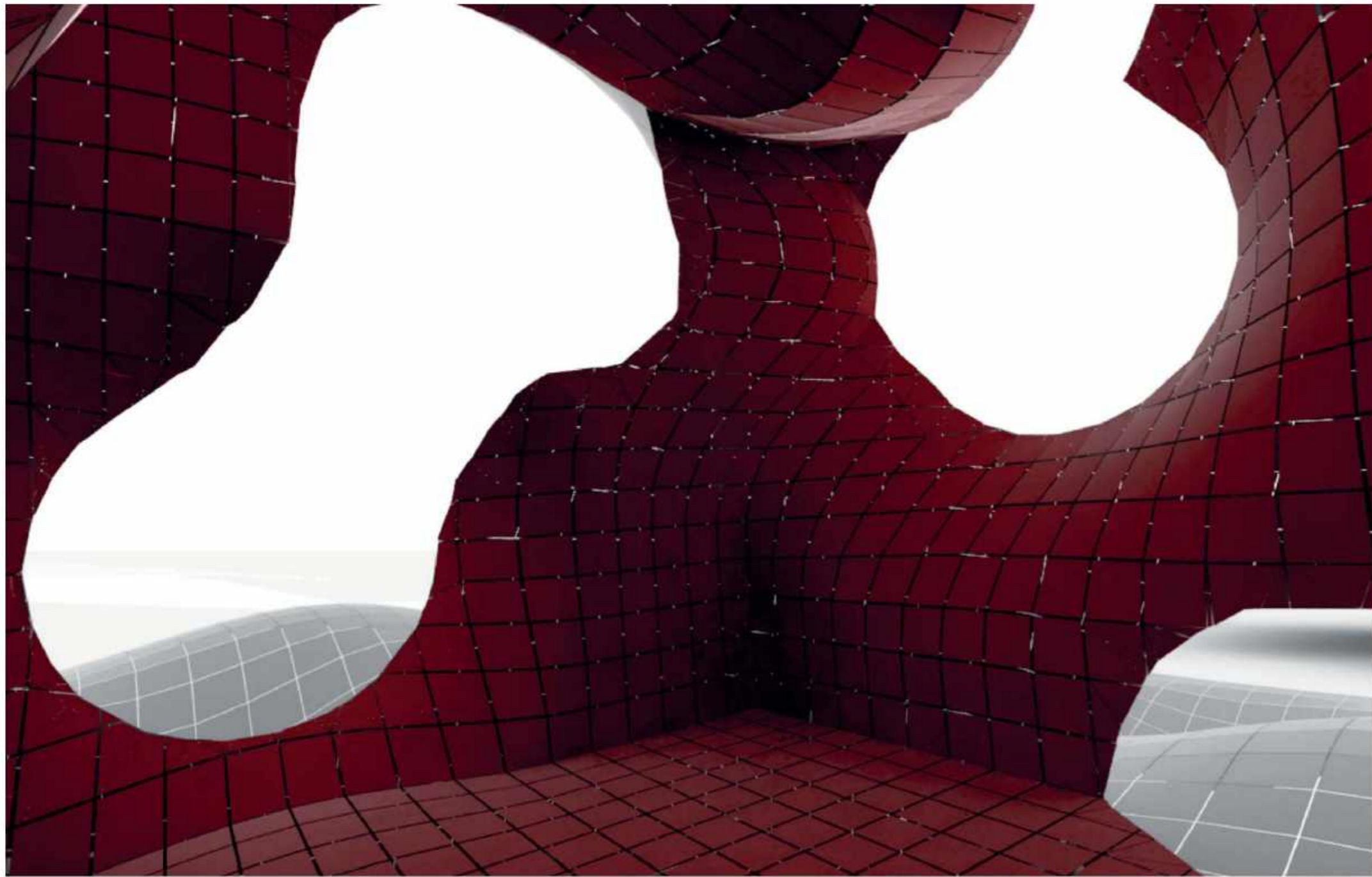

**RENDERED** VOID

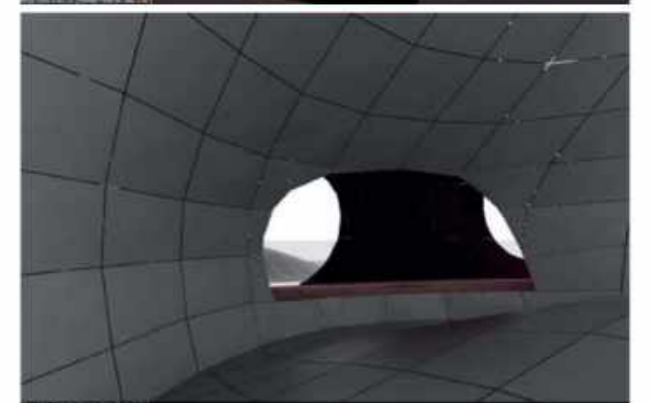

JOSEPH STUDIO LYNN WS09  
**MASSIVE** EFFECT



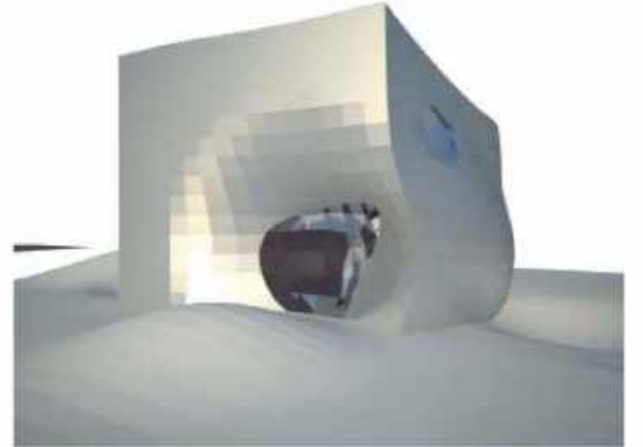
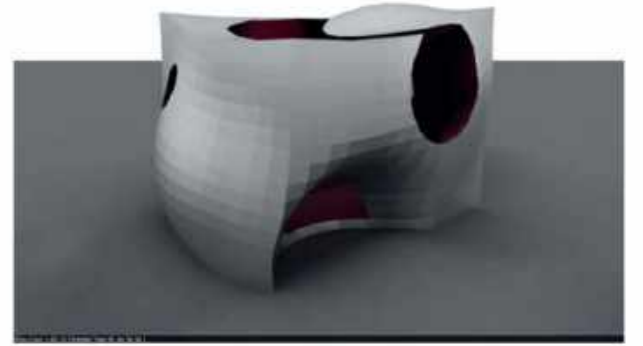
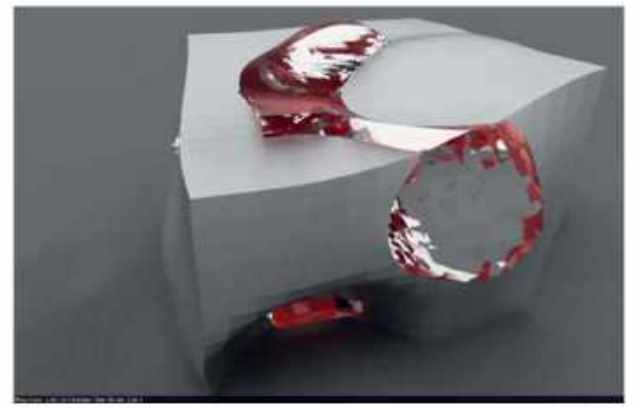
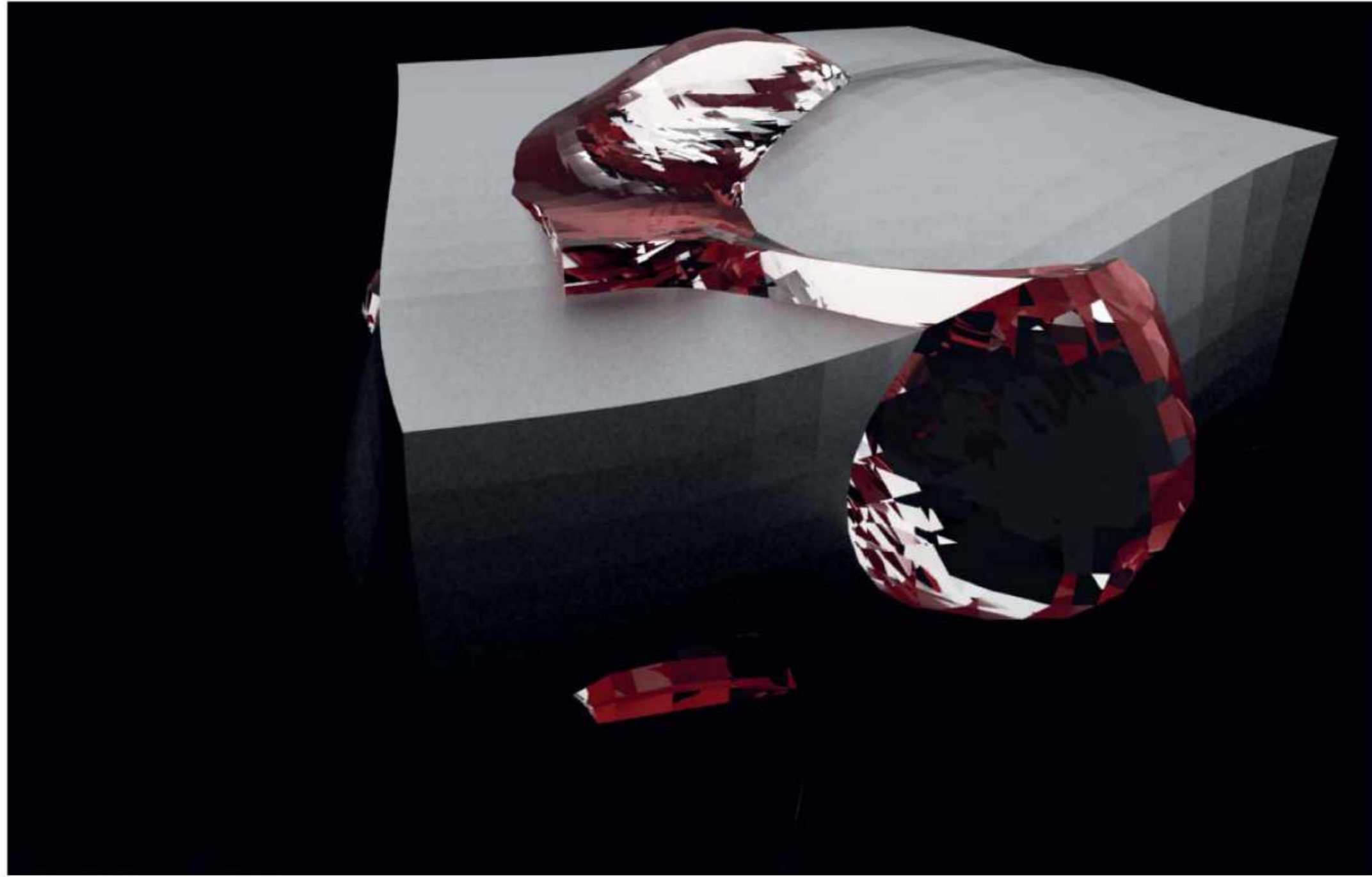

**RENDERED MASS**



**JOSEPH STUDIO LYNN WS09**  
**MASSIVE EFFECT**



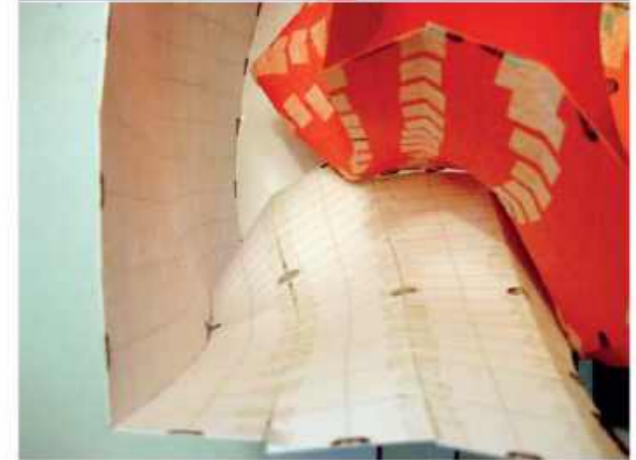
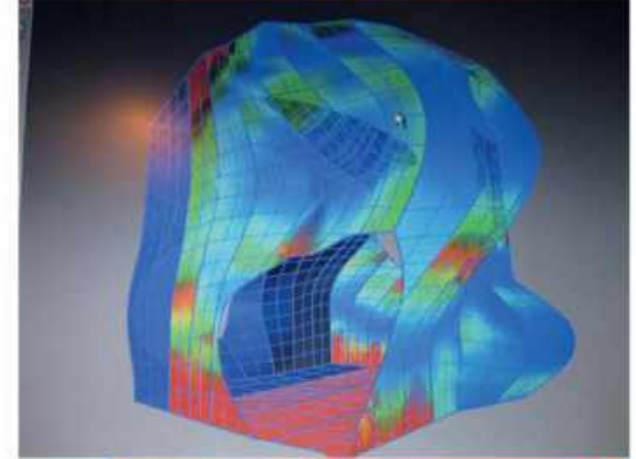
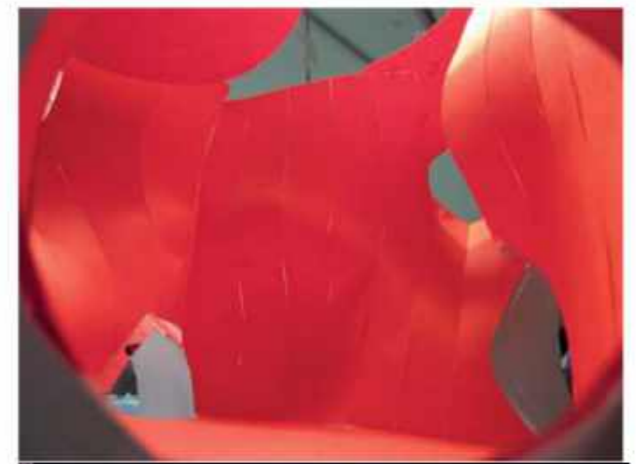
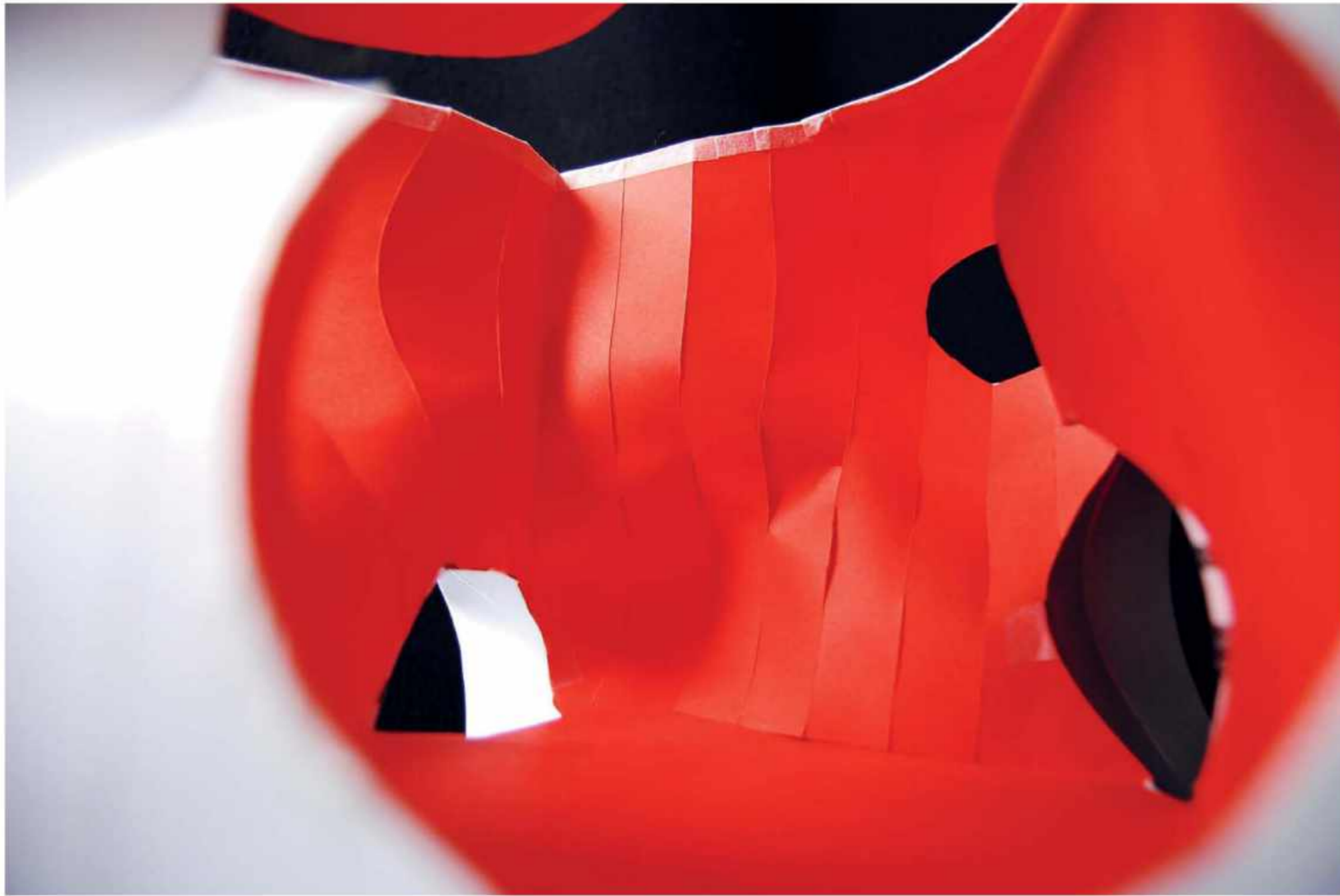

JOSEPH STUDIO LYNN WS09  
**MASSIVE** EFFECT



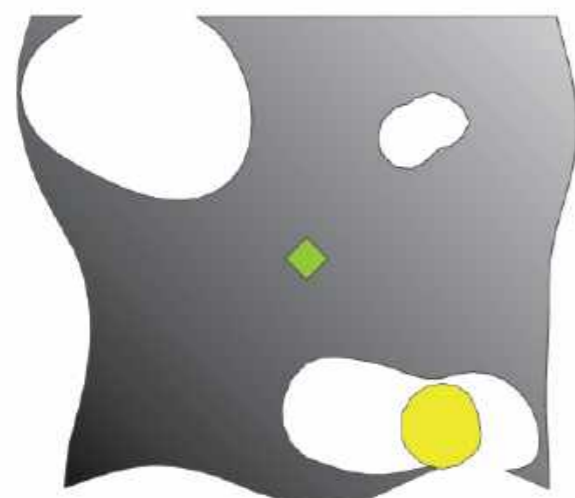
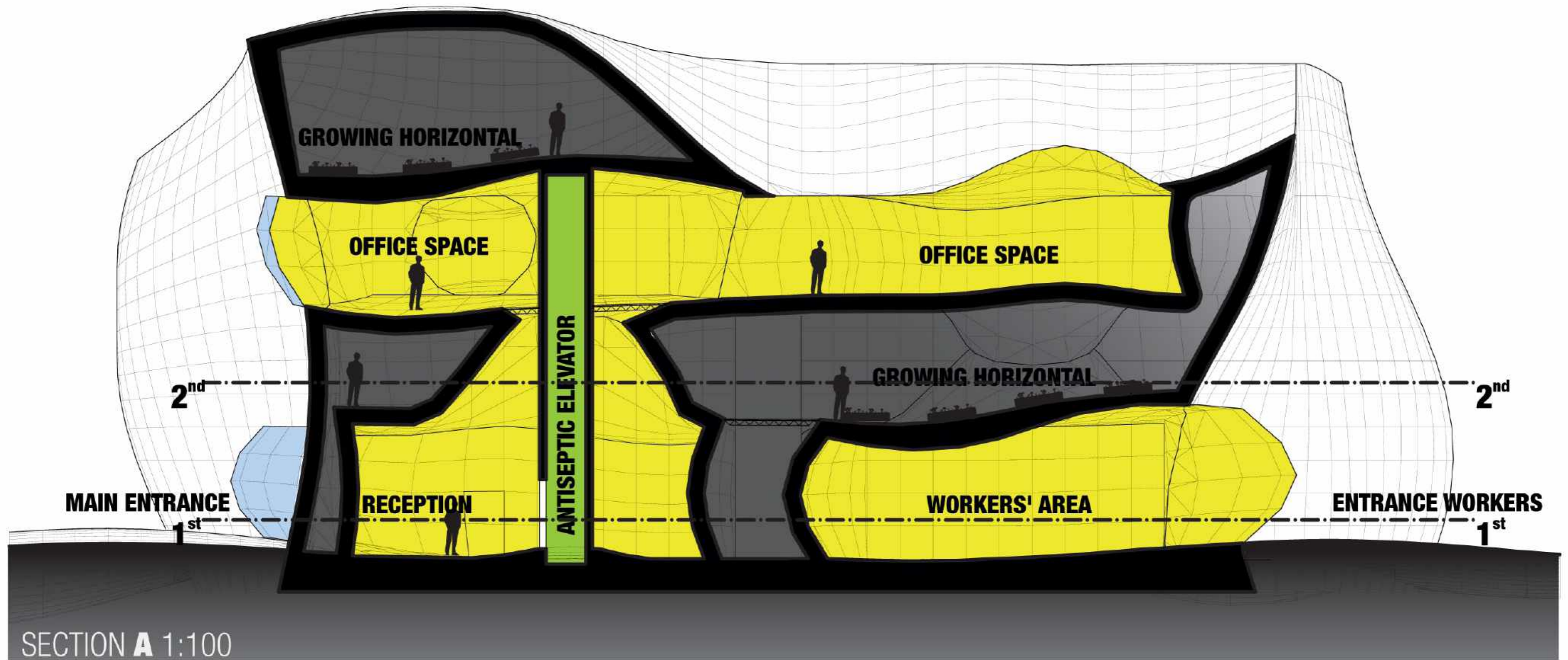

**FOURTH FLOOR**

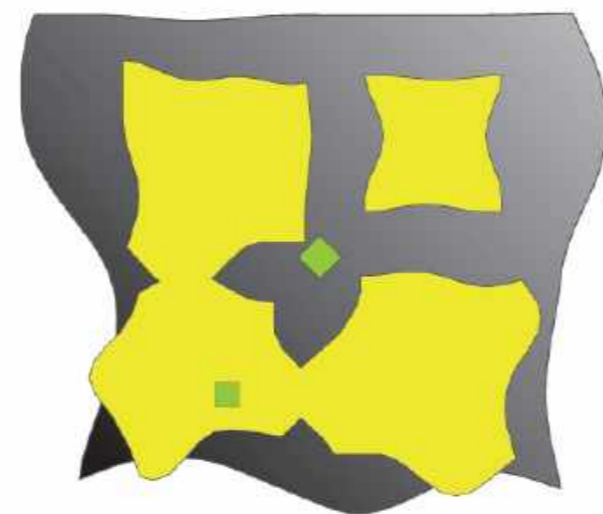

**THIRD FLOOR**



**SECOND FLOOR**



**FIRST FLOOR**



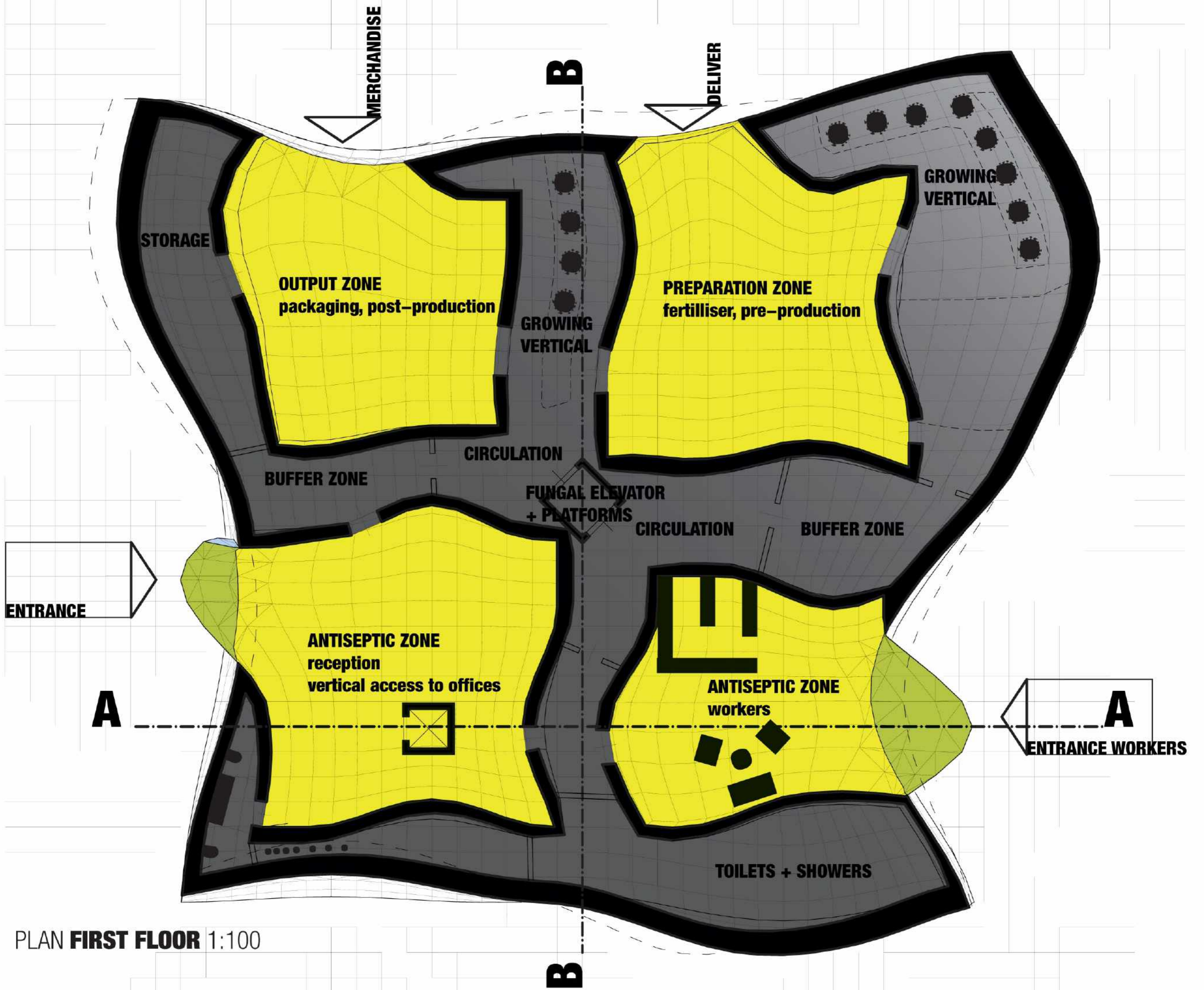

PLAN **FIRST FLOOR** 1:100



**PROGRAM**



cave à champignons

agricultural building for mushroom (agaricus bisporus) production

**POCHÉ/STRUCTURE**

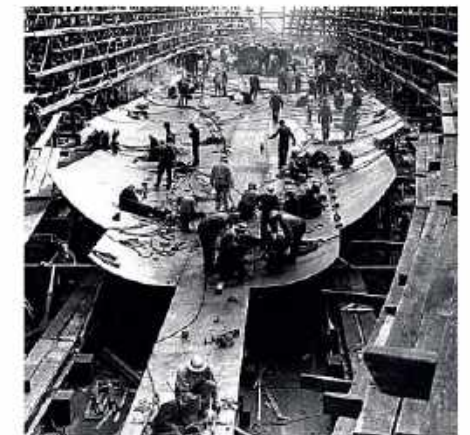

ship construction  
metal skins connected strongly

**GEOMETRY**



mechanically deformed  
inertial material  
expresses mass

**CLIMATE**



cave like

no daylight, constant humidity & temperature  
work with earth mass and PCM (phase changing material)

**BUILDING TO GROUND**

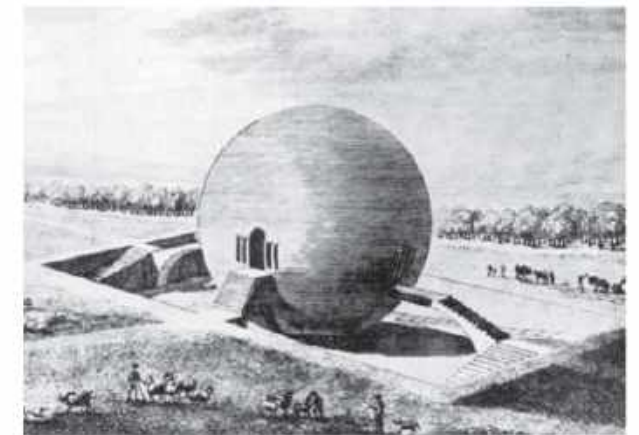

ground carved out in similar volume as  
building or poché volume

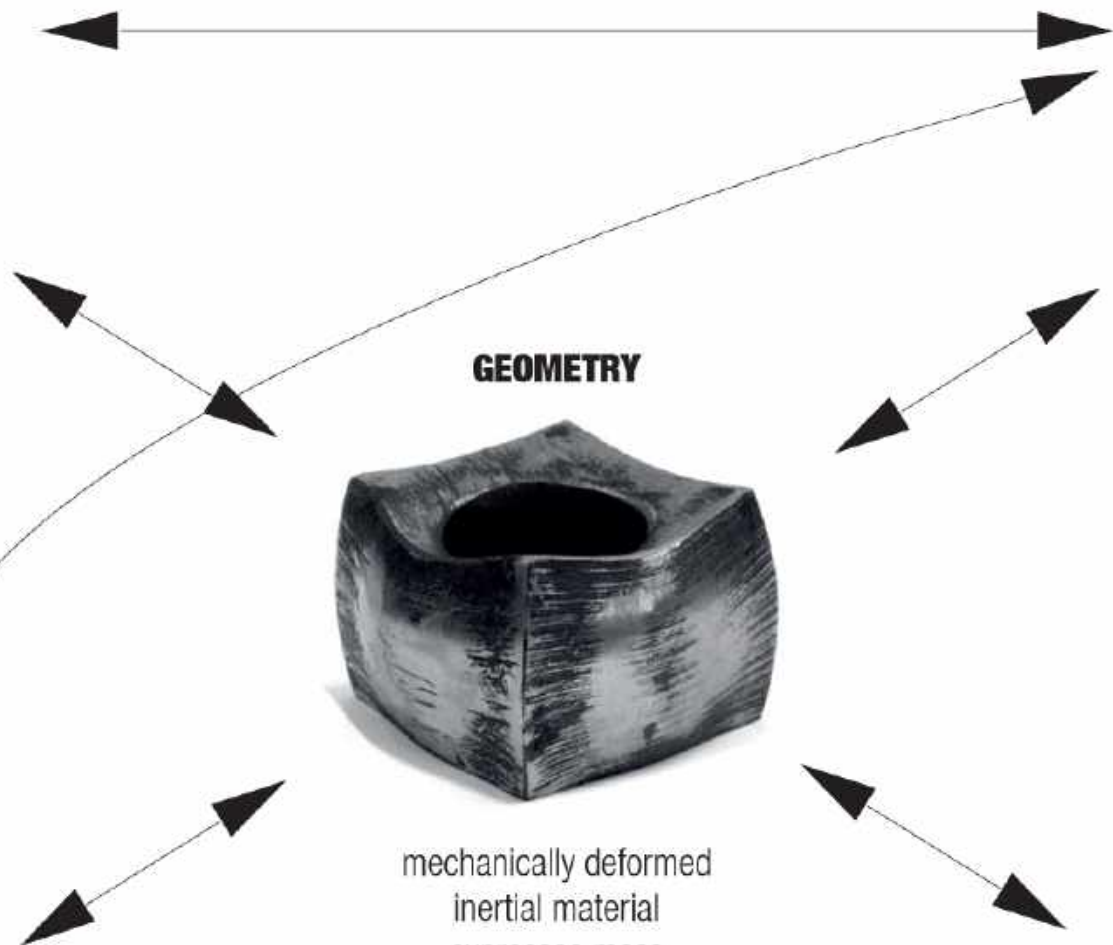

RELATIONS OF **DESIGN ASPECTS**



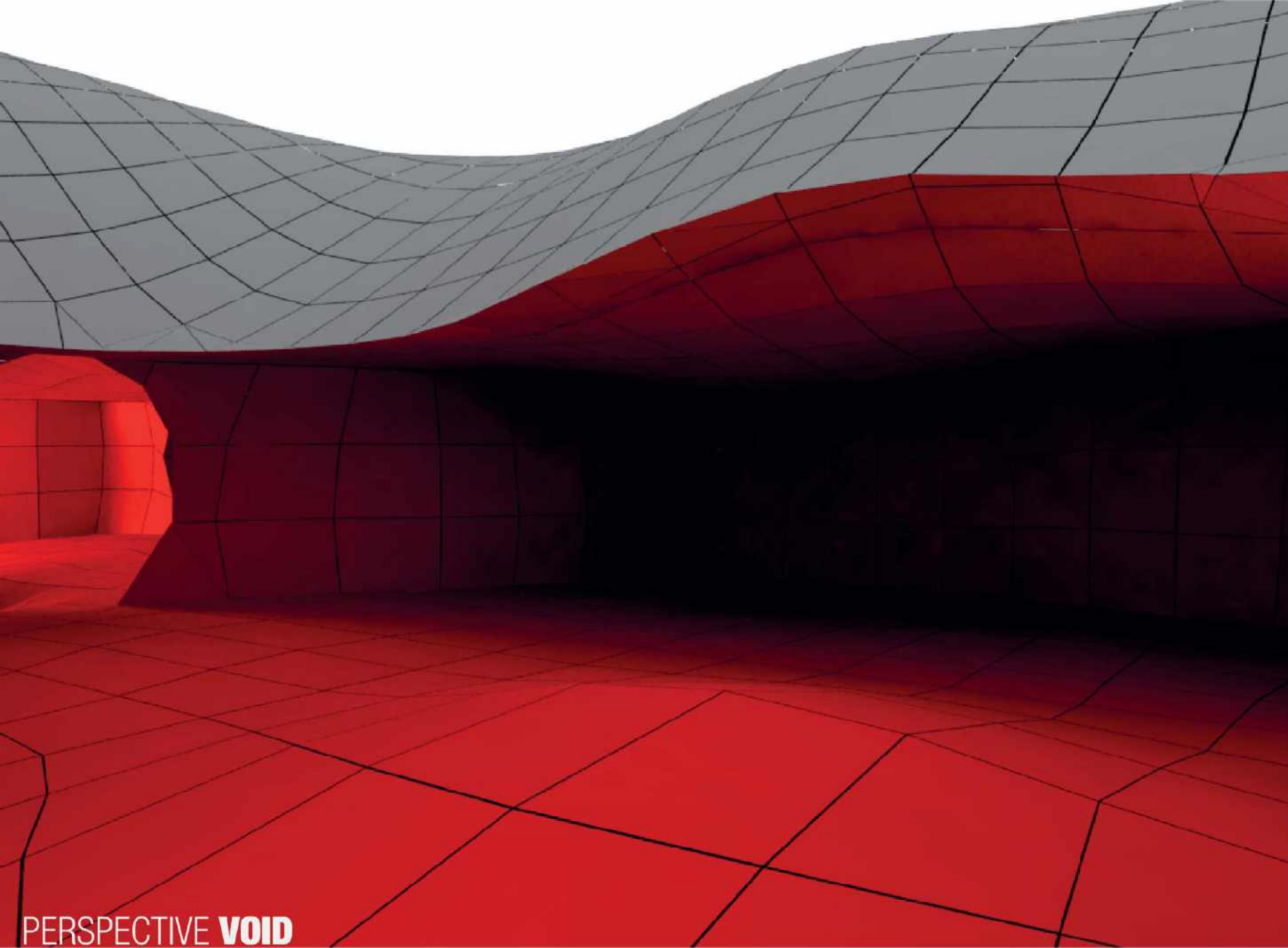

PERSPECTIVE **VOID**



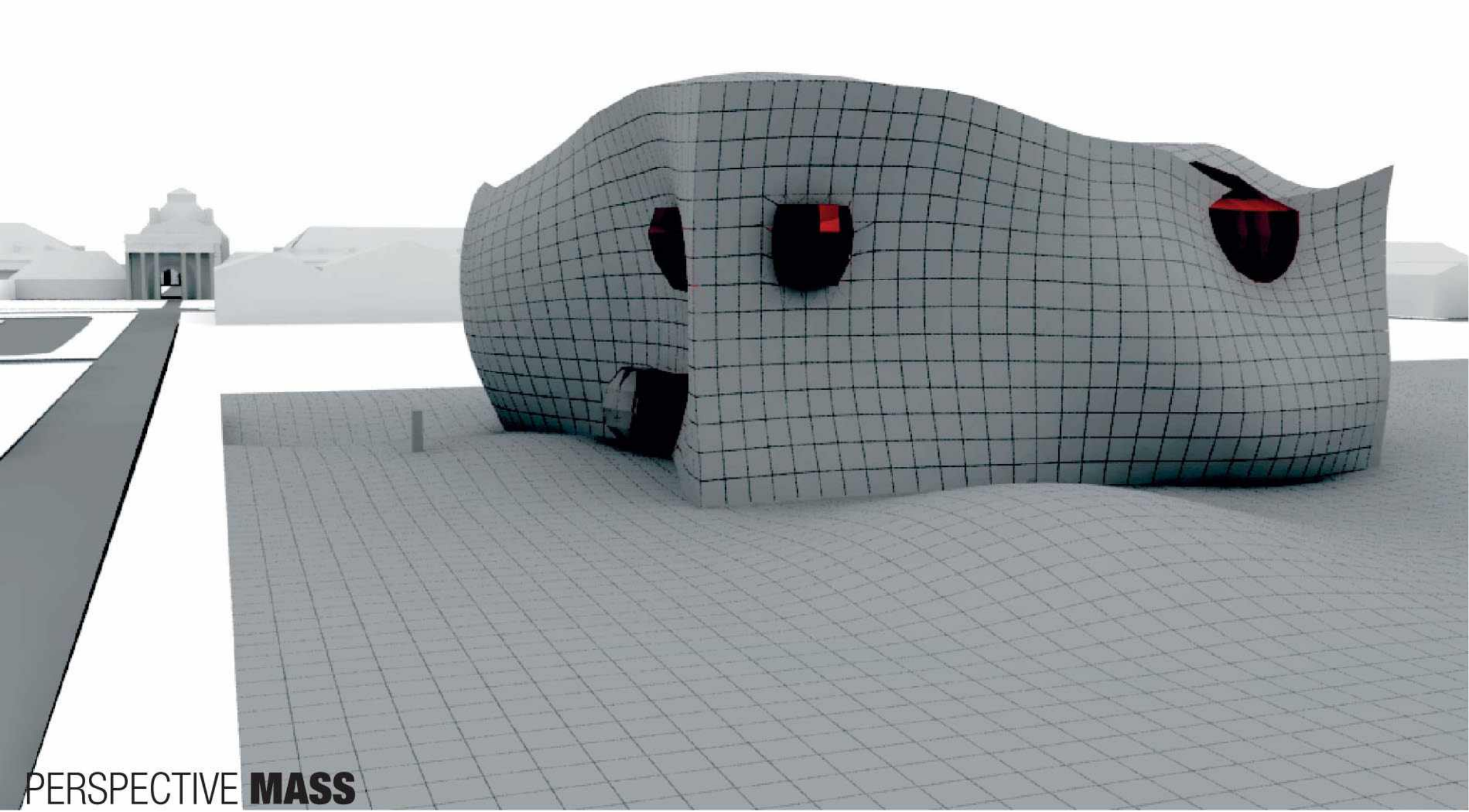

PERSPECTIVE **MASS**



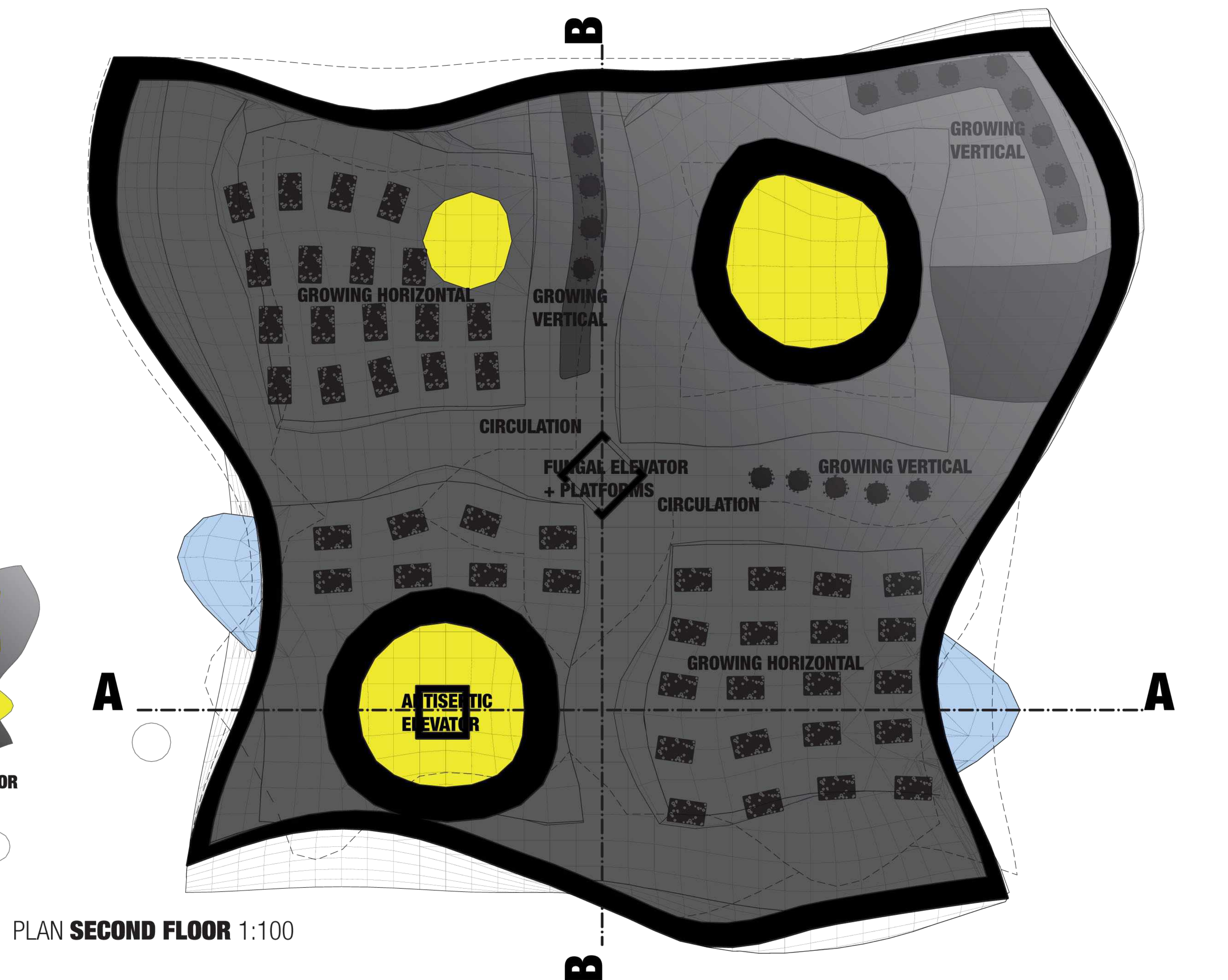
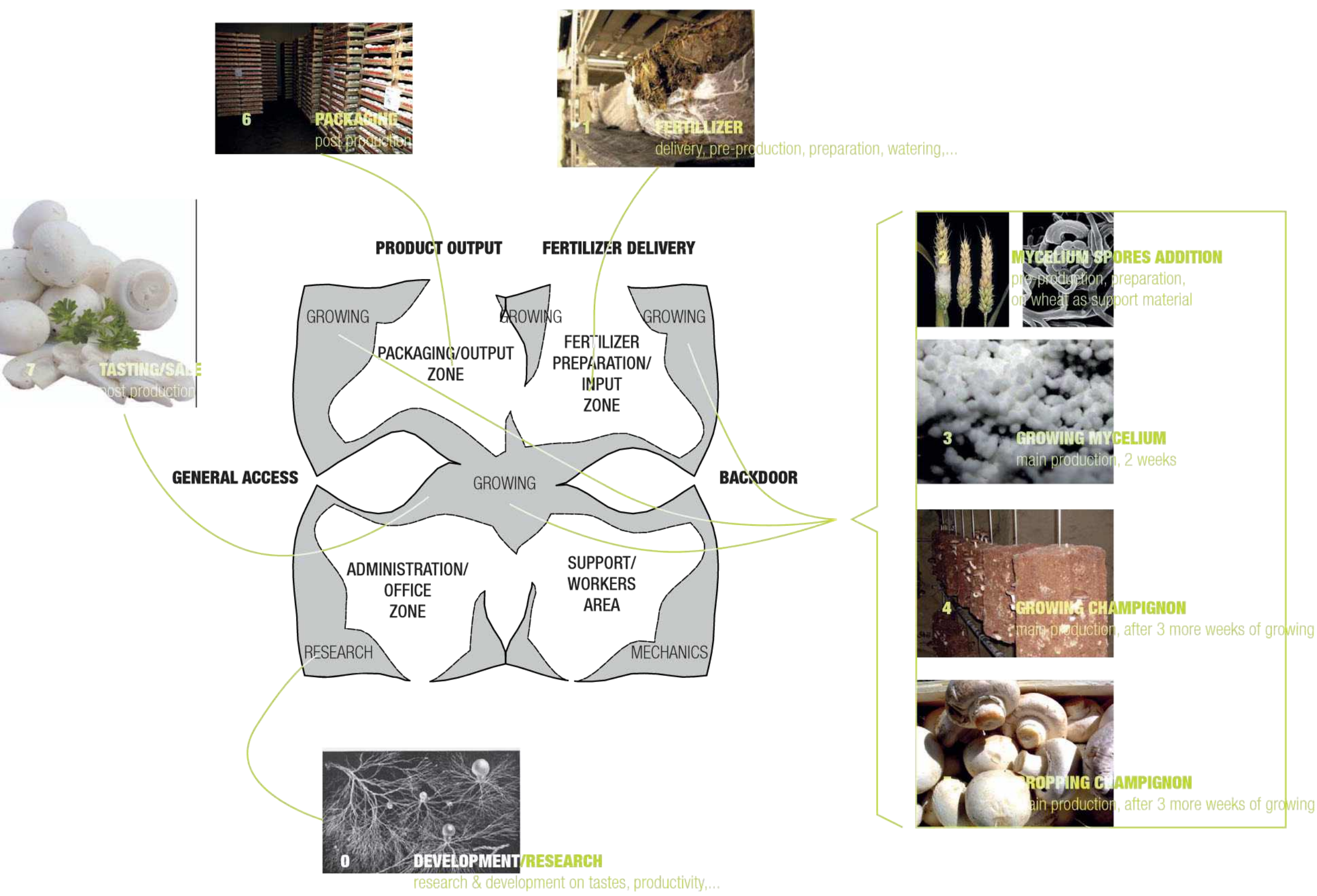
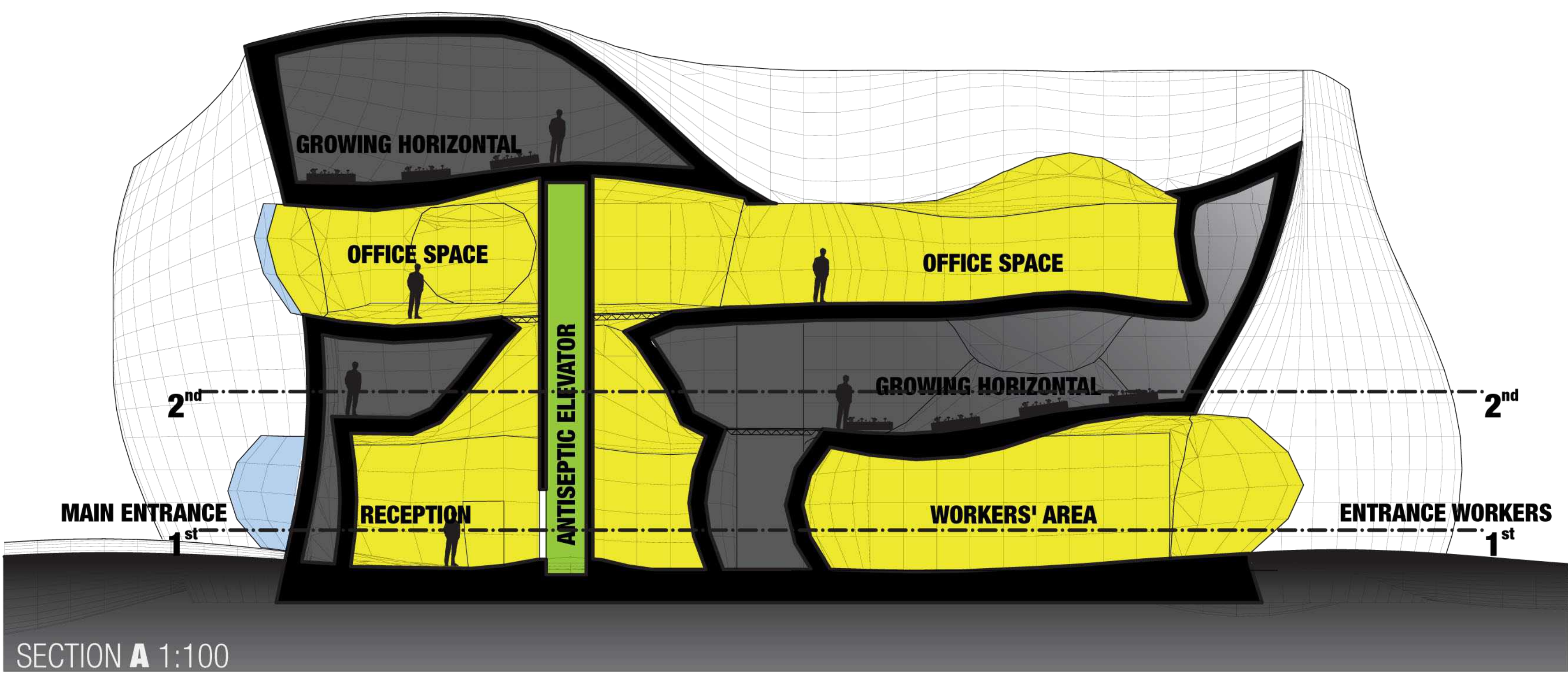
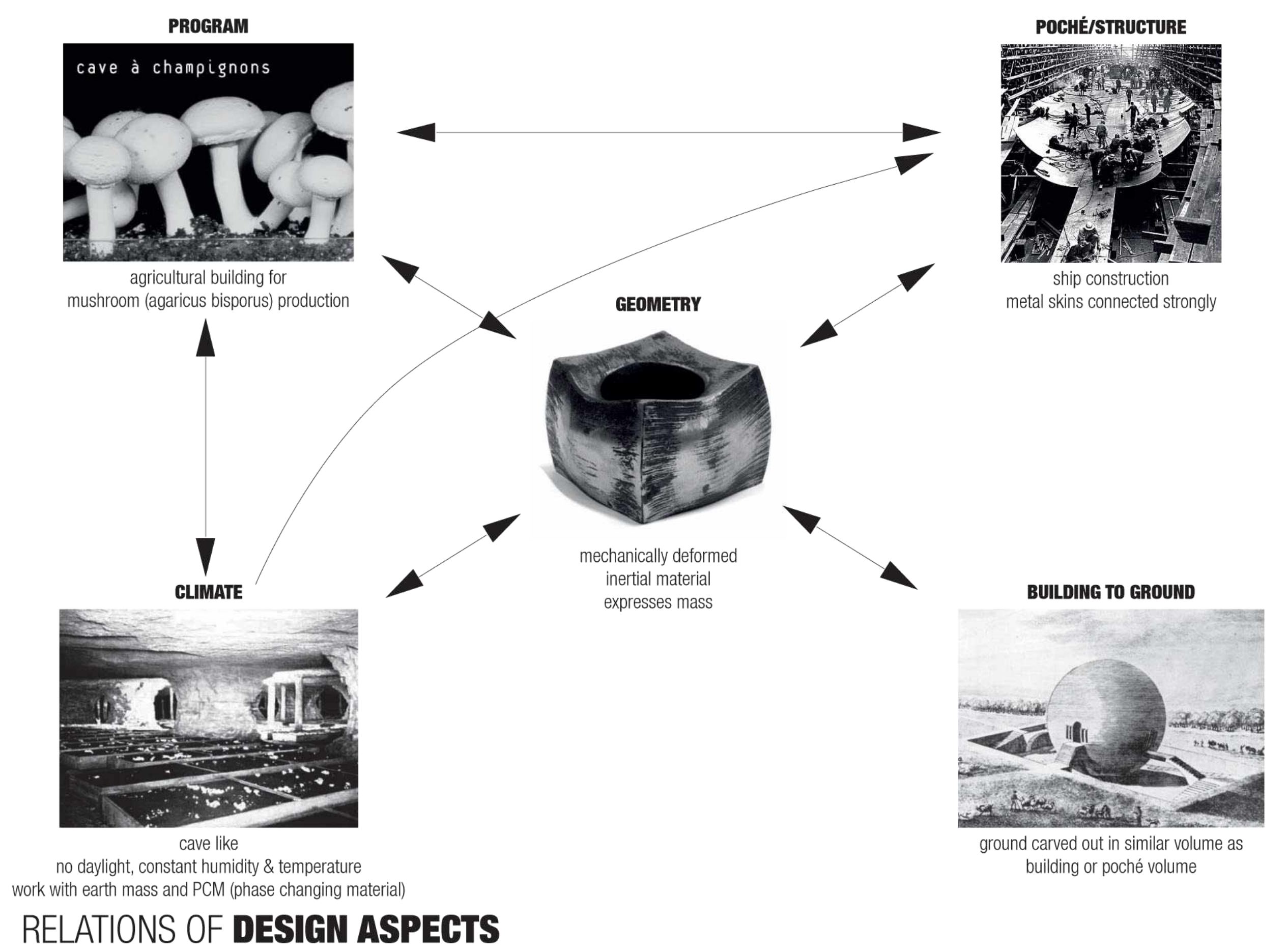
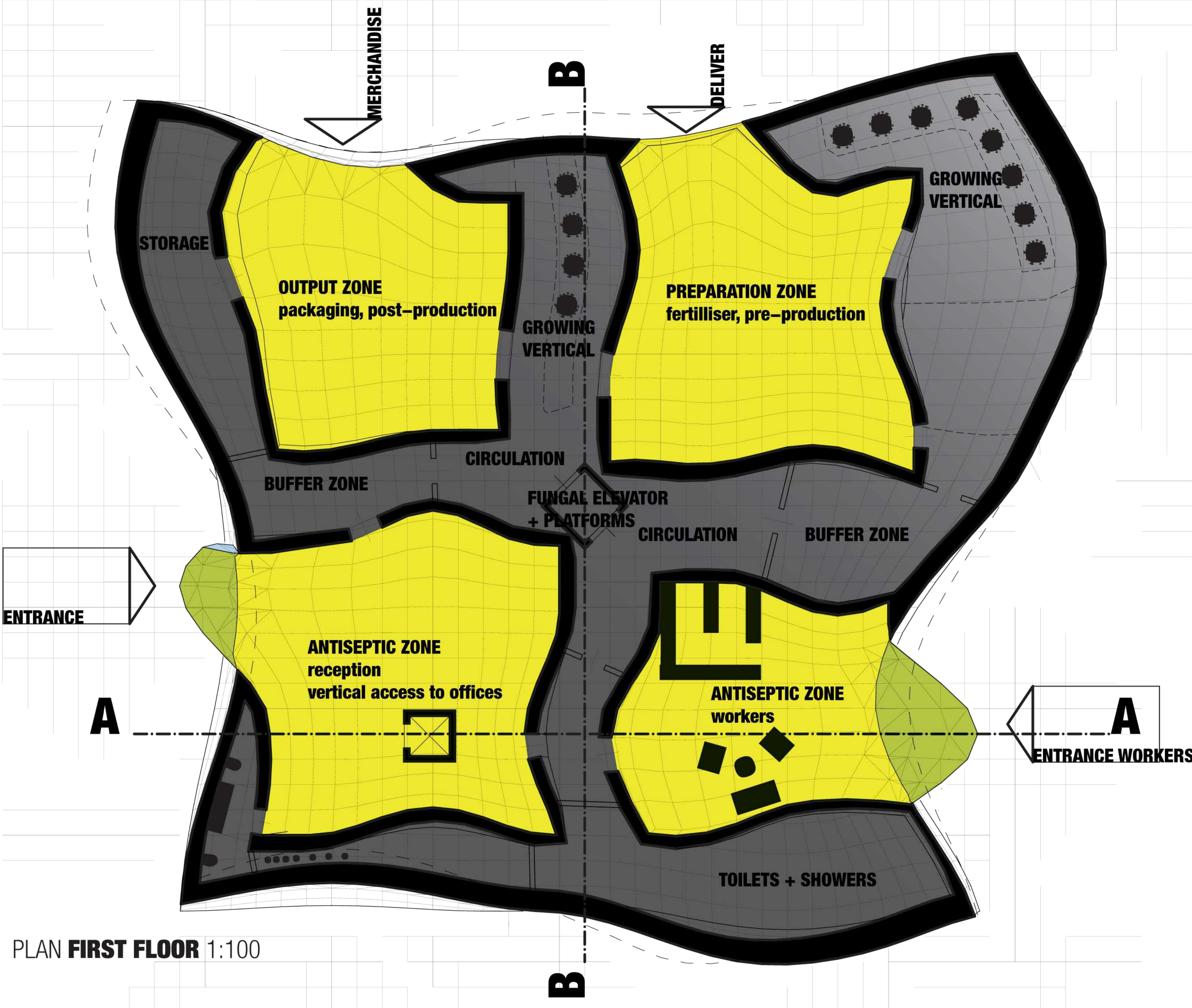
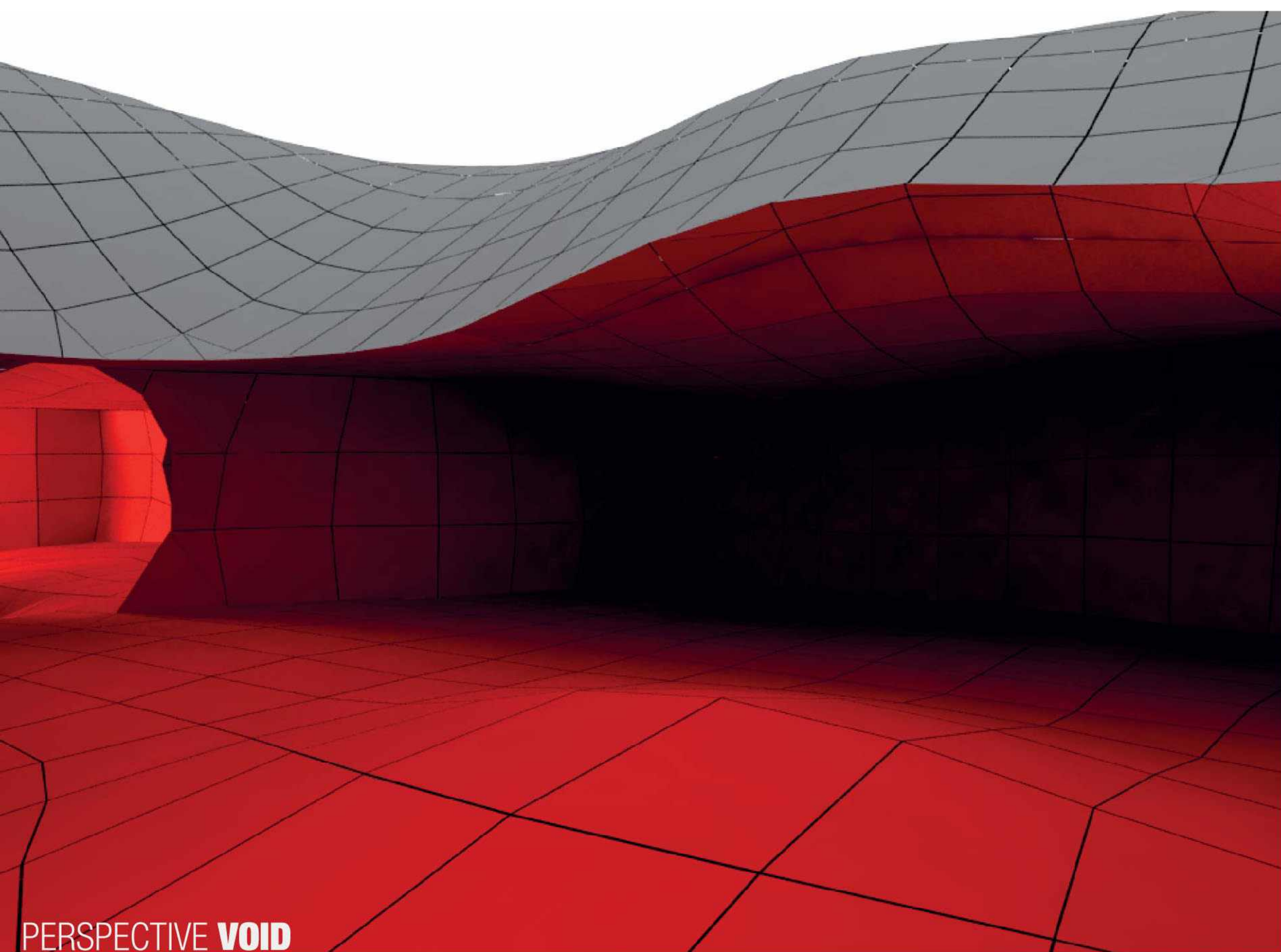
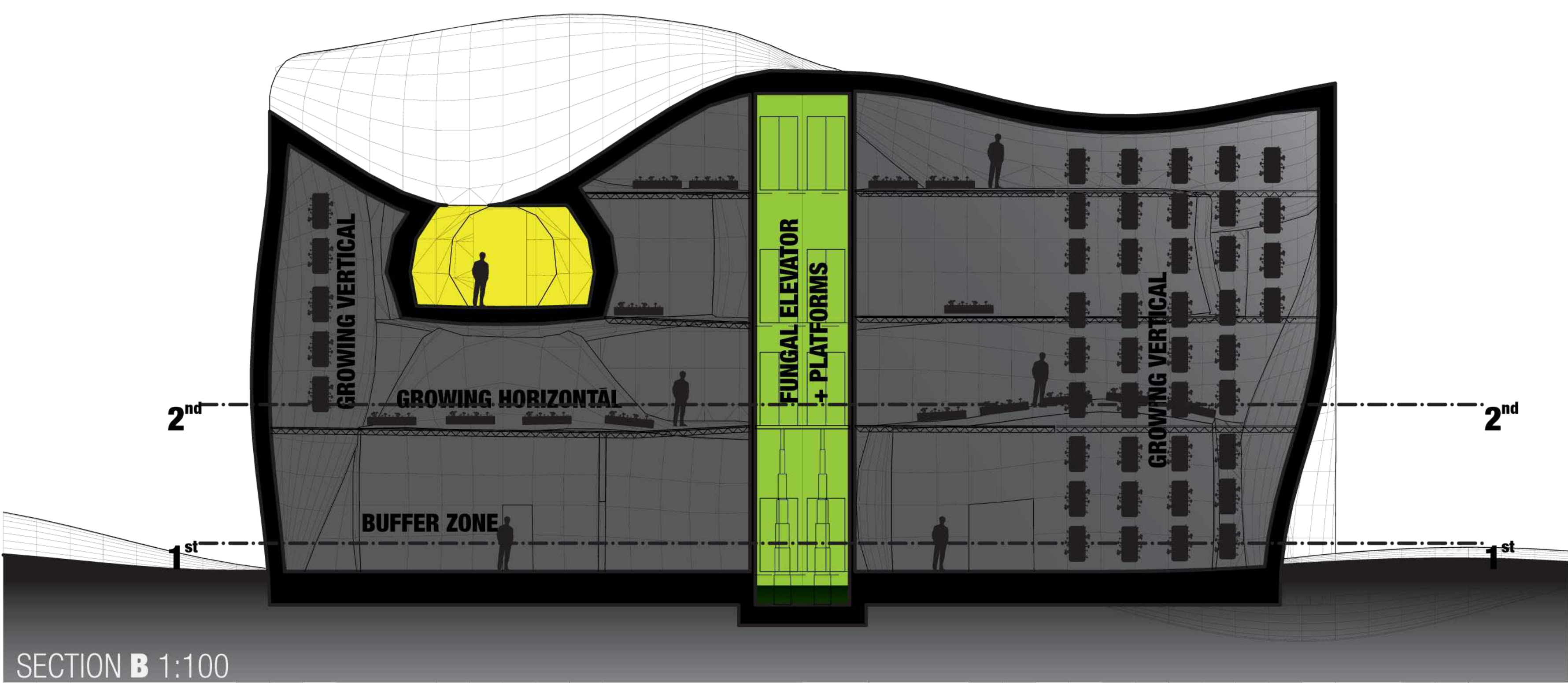
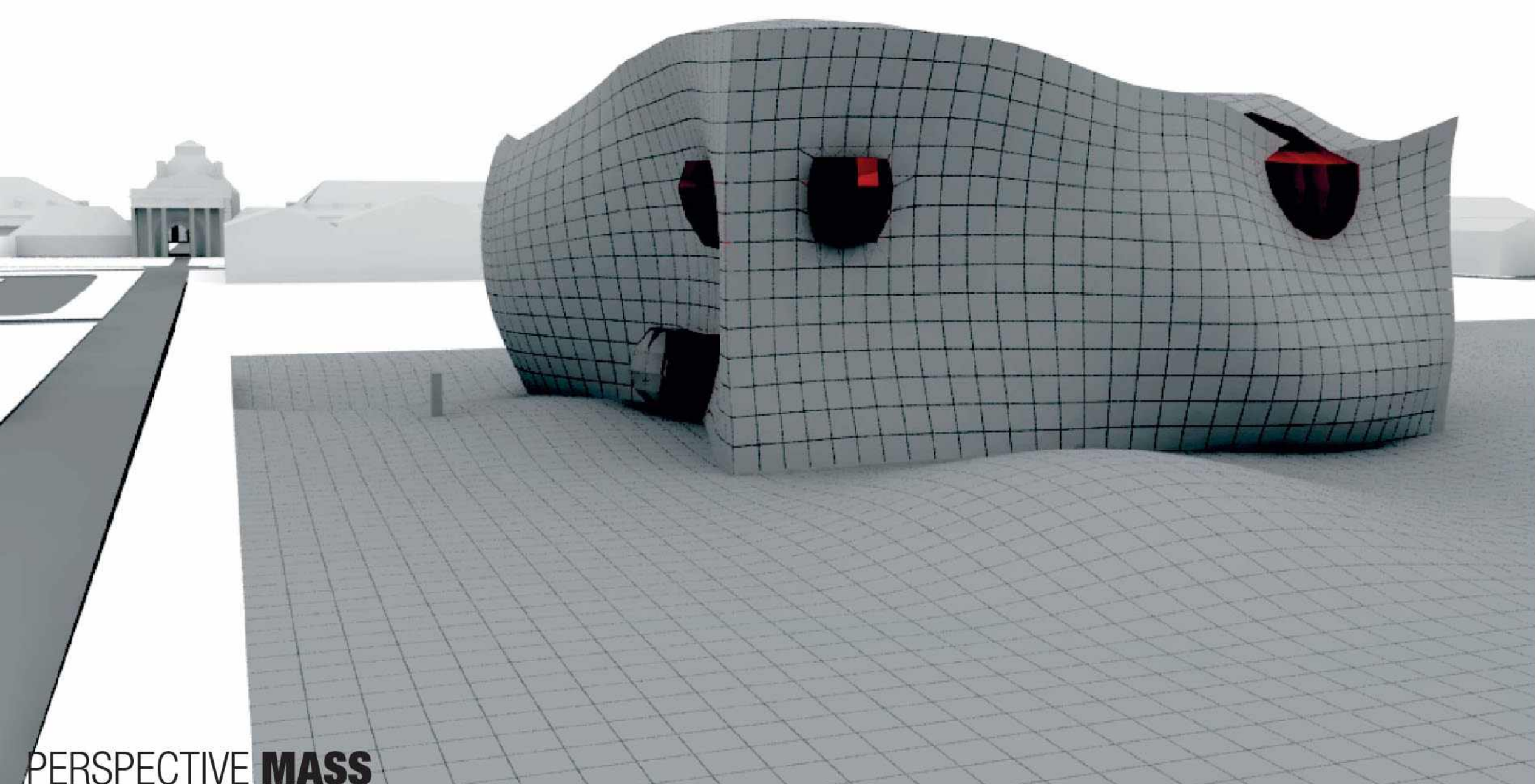

**STATEMENT**  
 MASS = INERTIAL  
 my mass language should be translated by punching bumps into an inertial material.  
 punching happens from outside as well as from the inside. so the intersection between mass and void surface results as aperture.  
 as mass physically is inertial, mechanically deformed iron (p.e.) feels massive -> the architecture is massive in expression.  
 the mass effect is realized as punched geometry.



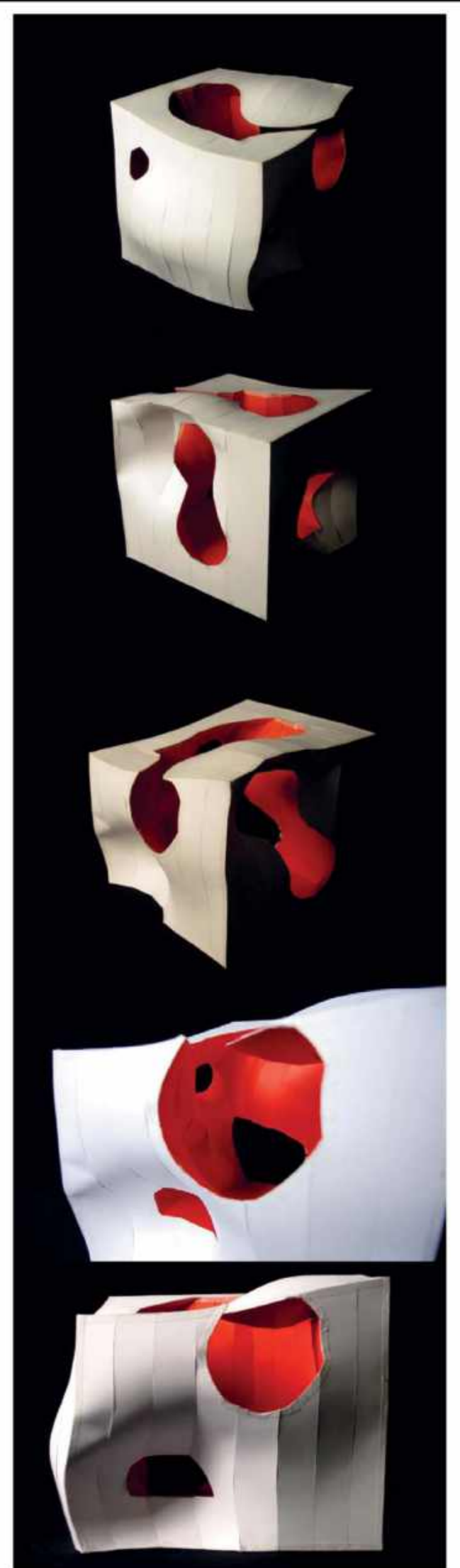
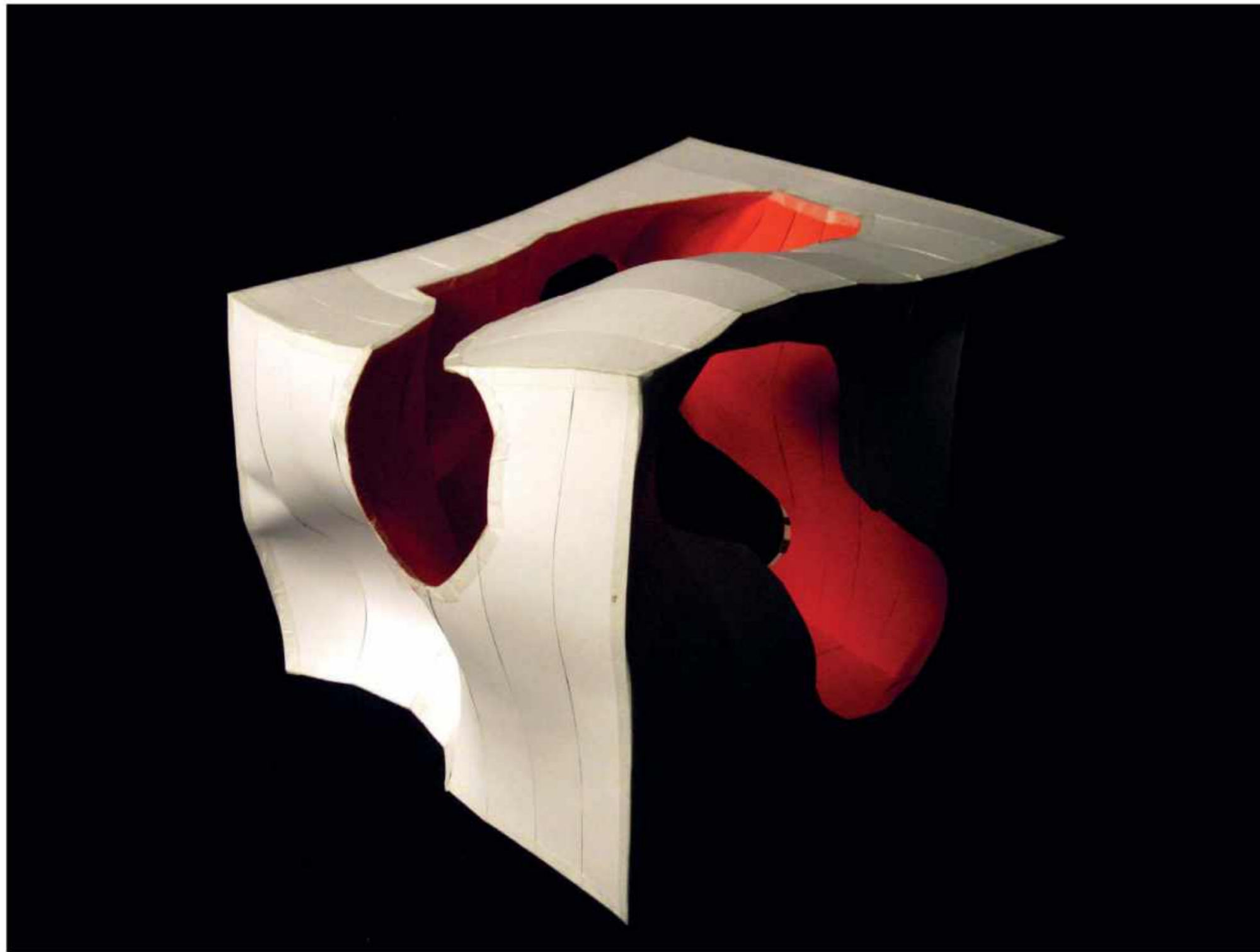

JOSEPH STUDIO LYNN WS09  
**MASSIVE** EFFECT



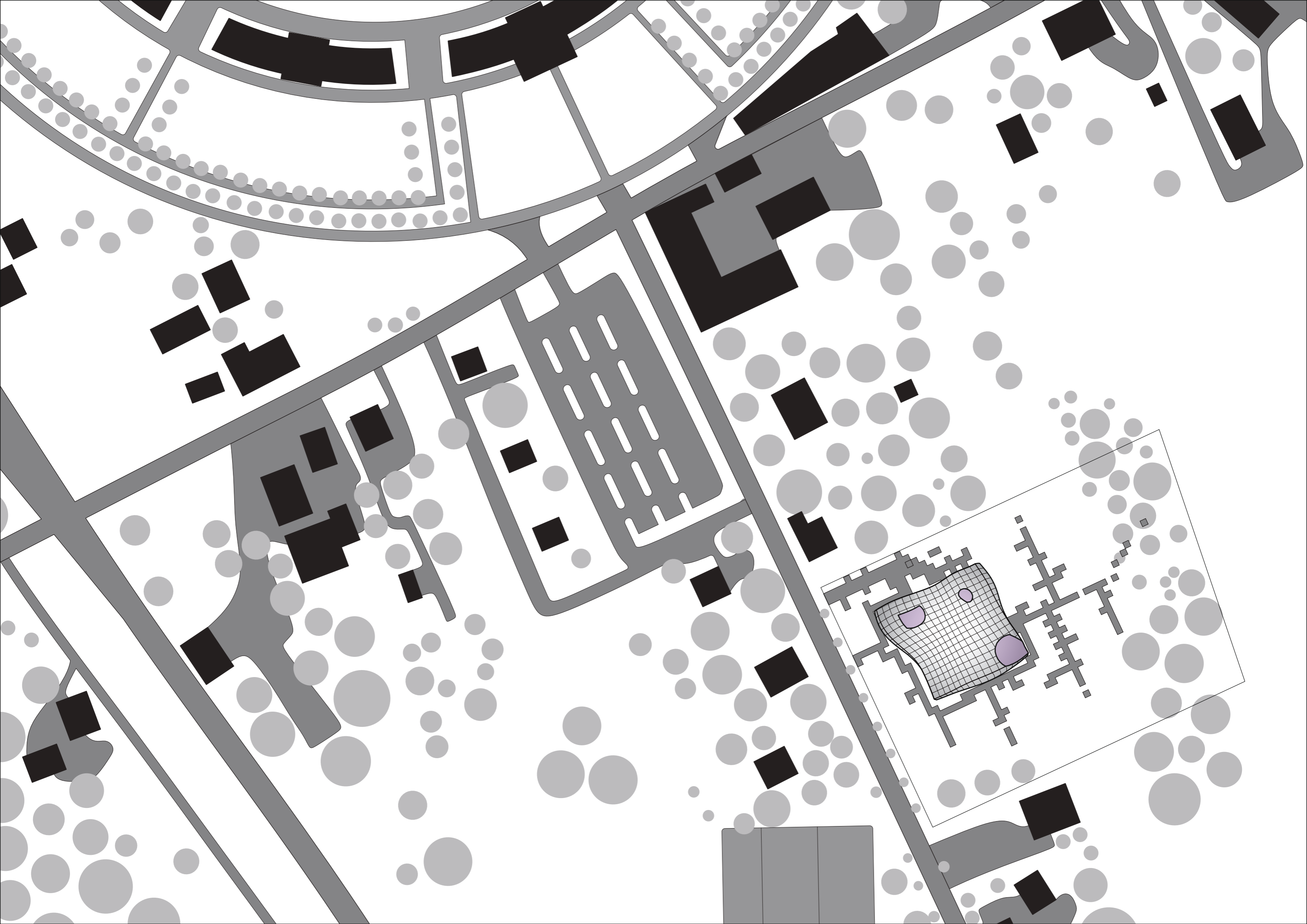



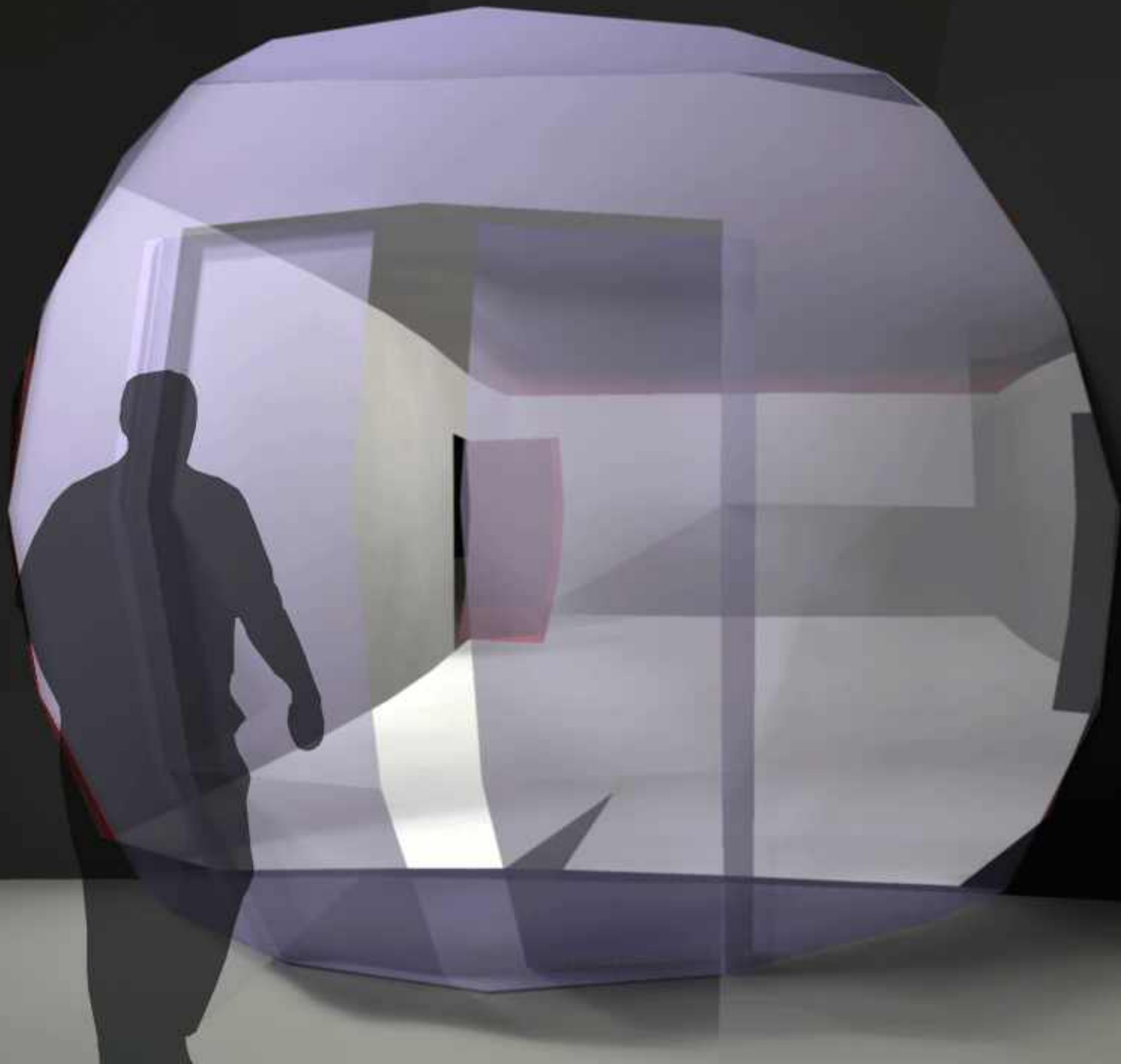



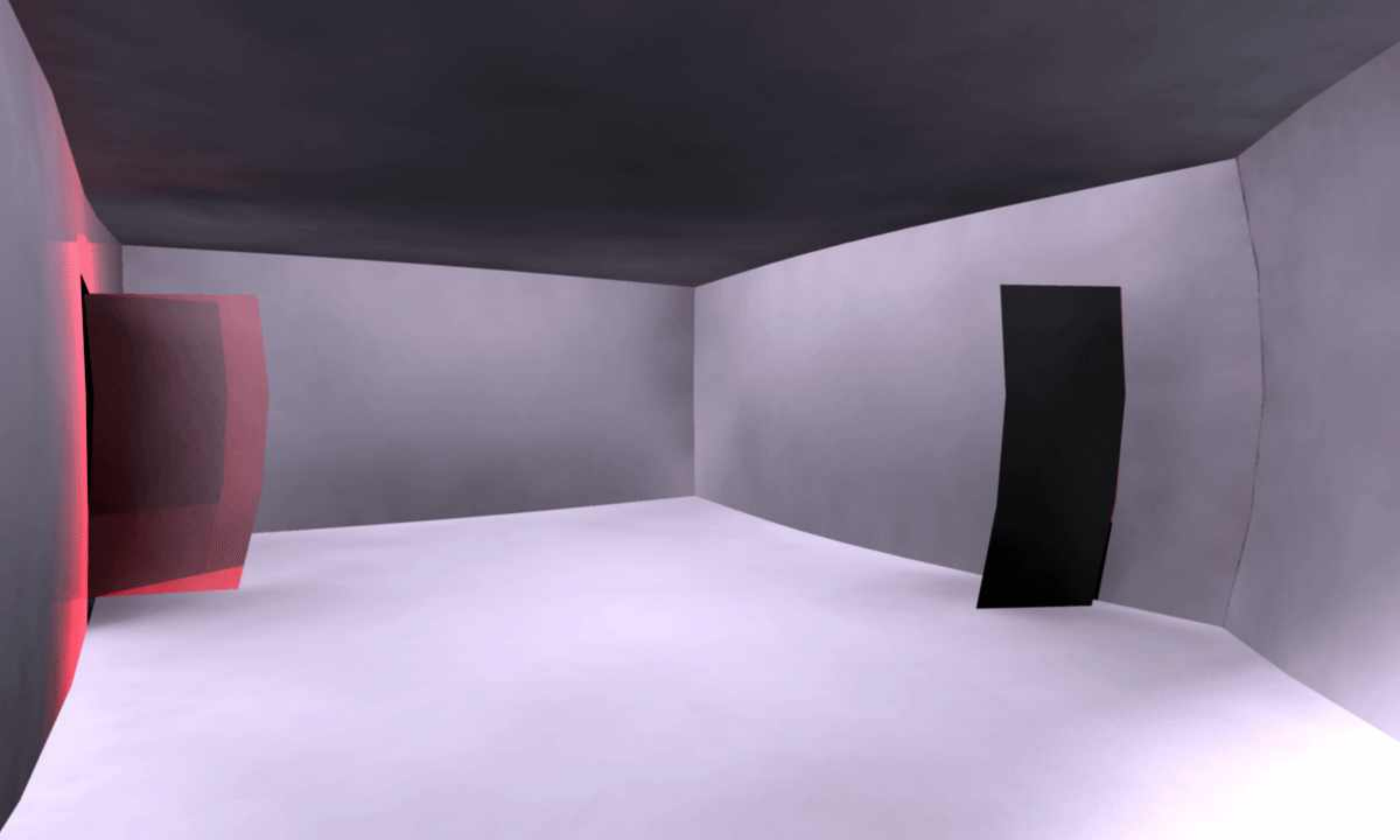



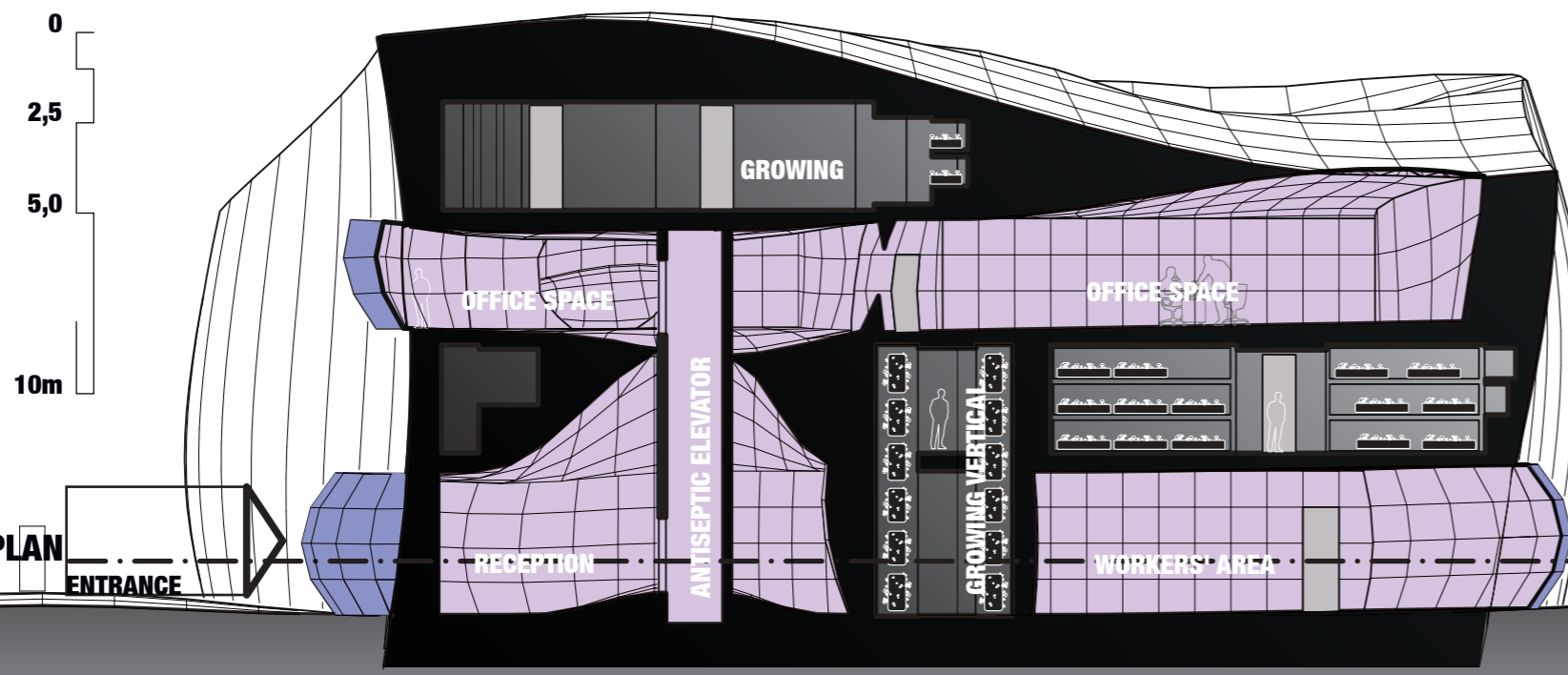
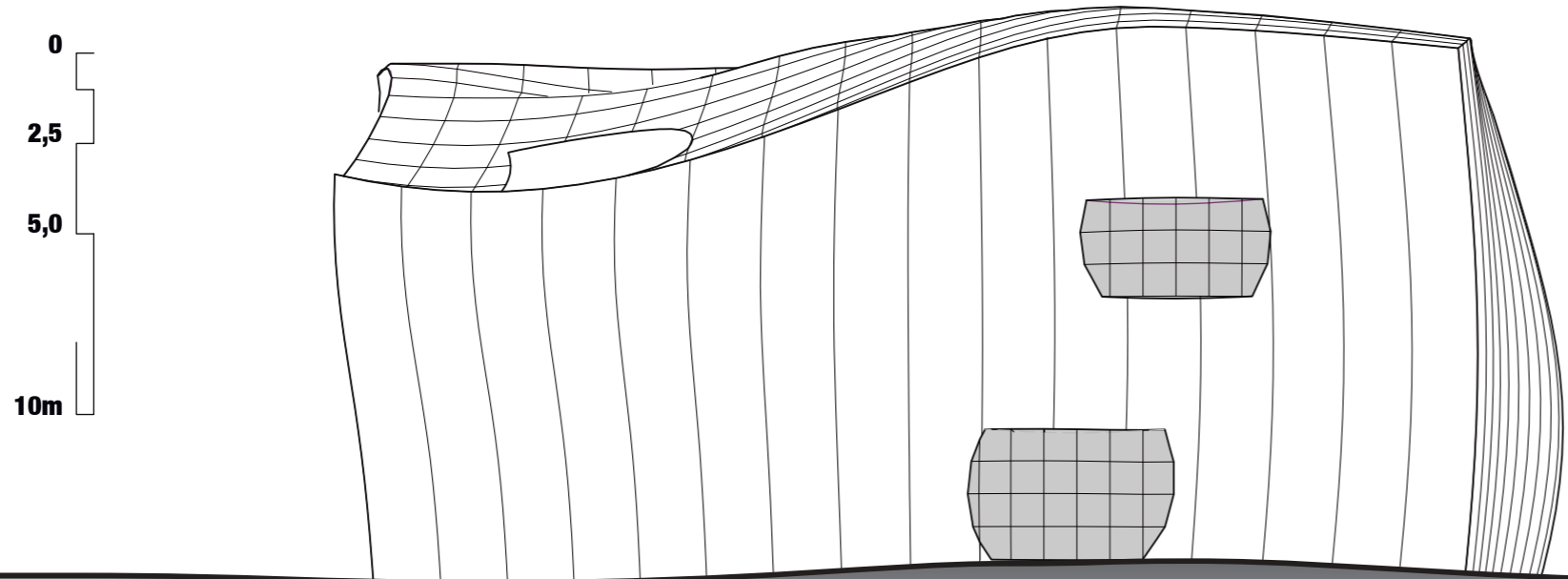

FIRST FLOOR PLAN

ENTRANCE

RECEPTION

ANTISEPTIC ELEVATOR

GROWING VERTICAL

WORKERS' AREA

ENTRANCE WORKERS

FIRST FLOOR PLAN

GROWING

OFFICE SPACE

OFFICE SPACE



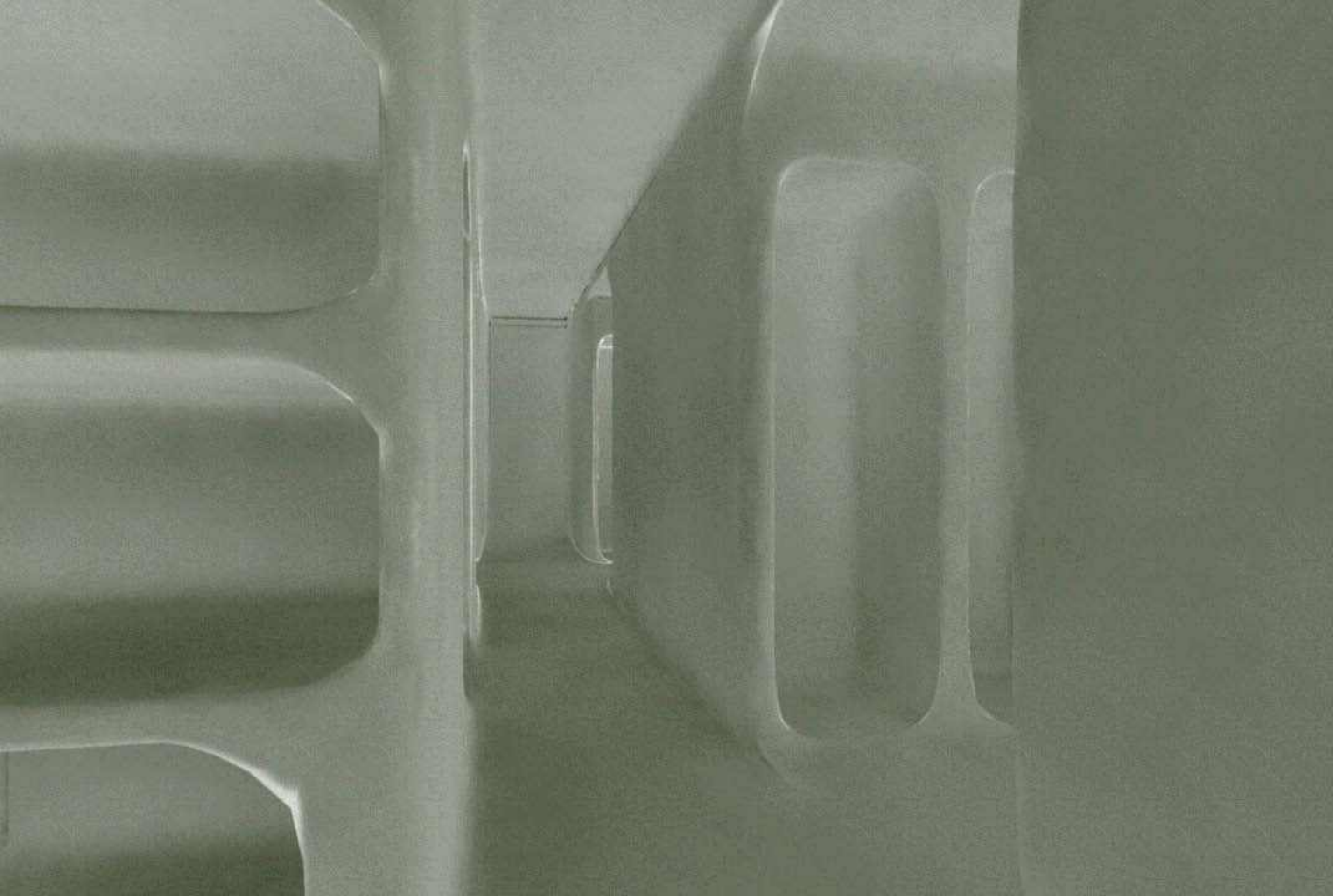



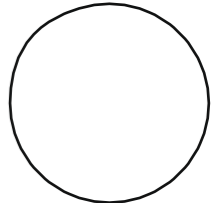
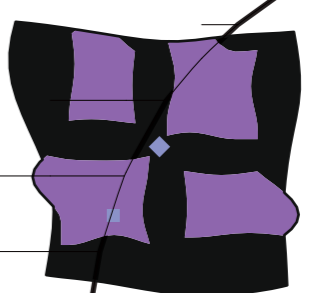
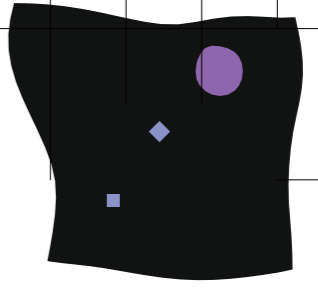
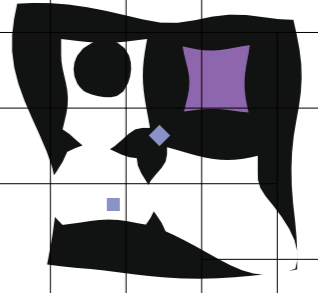
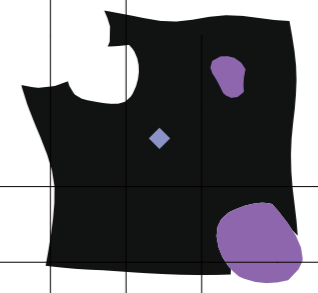
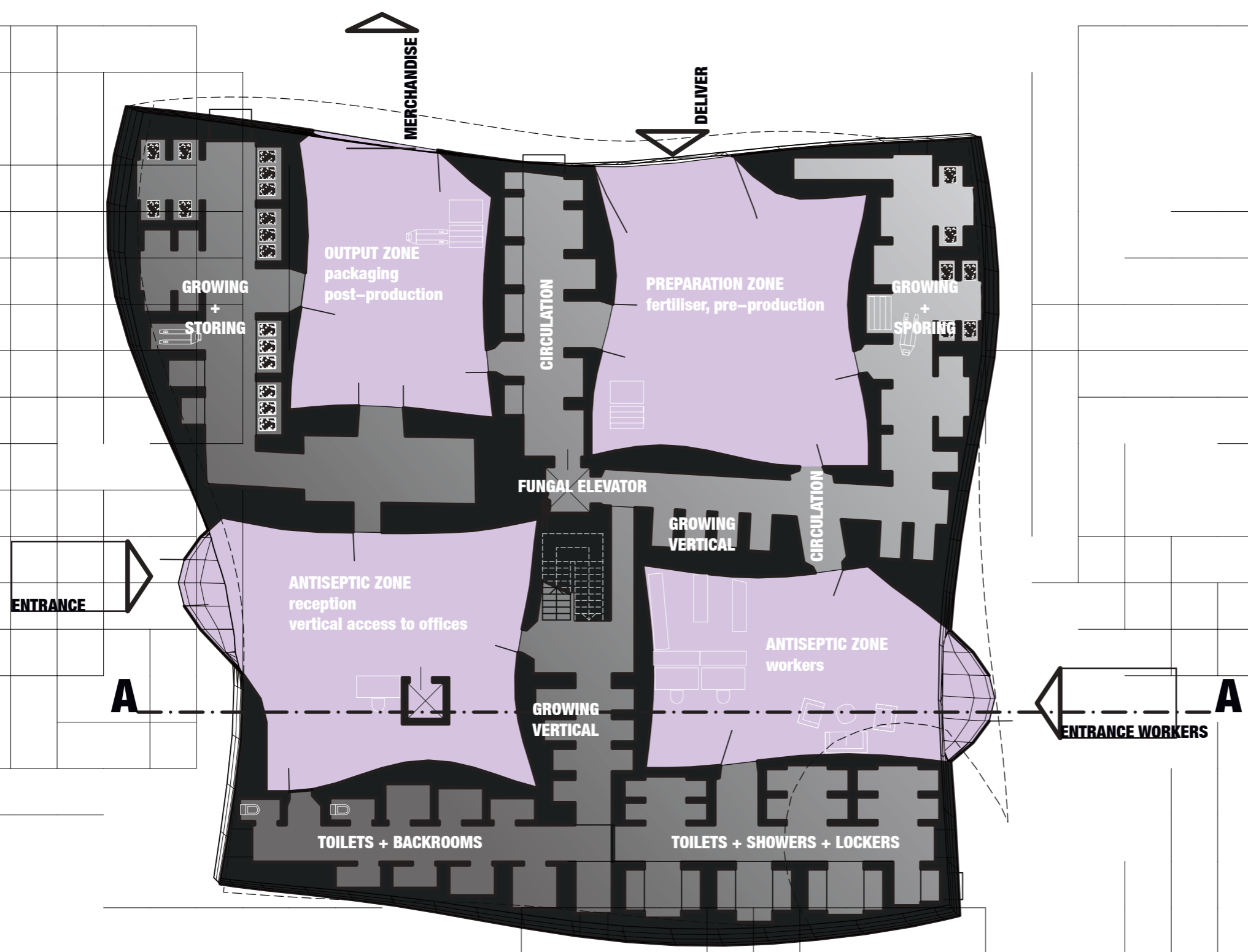
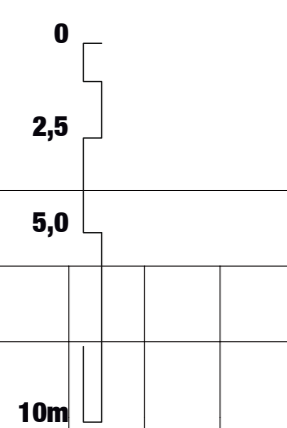



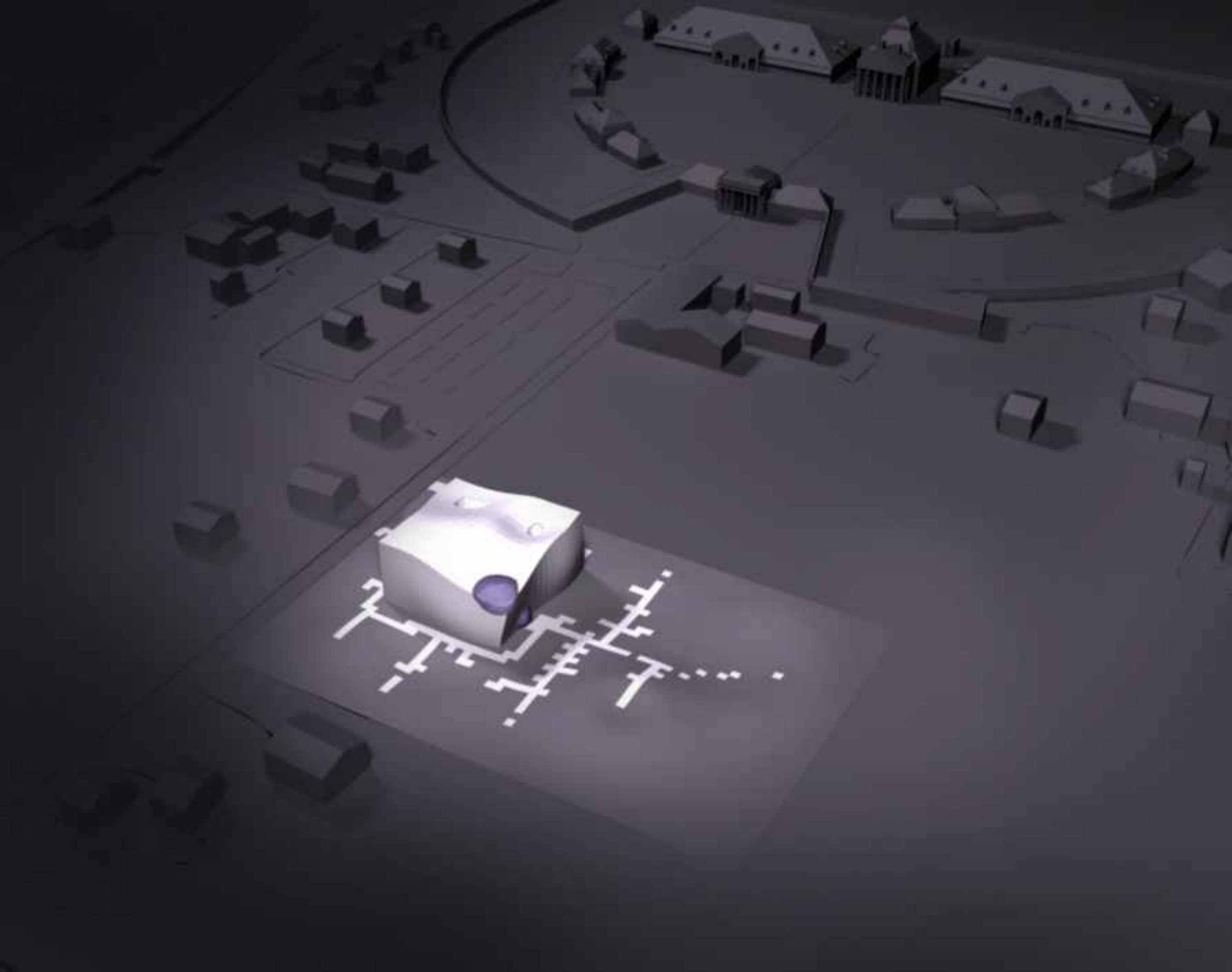



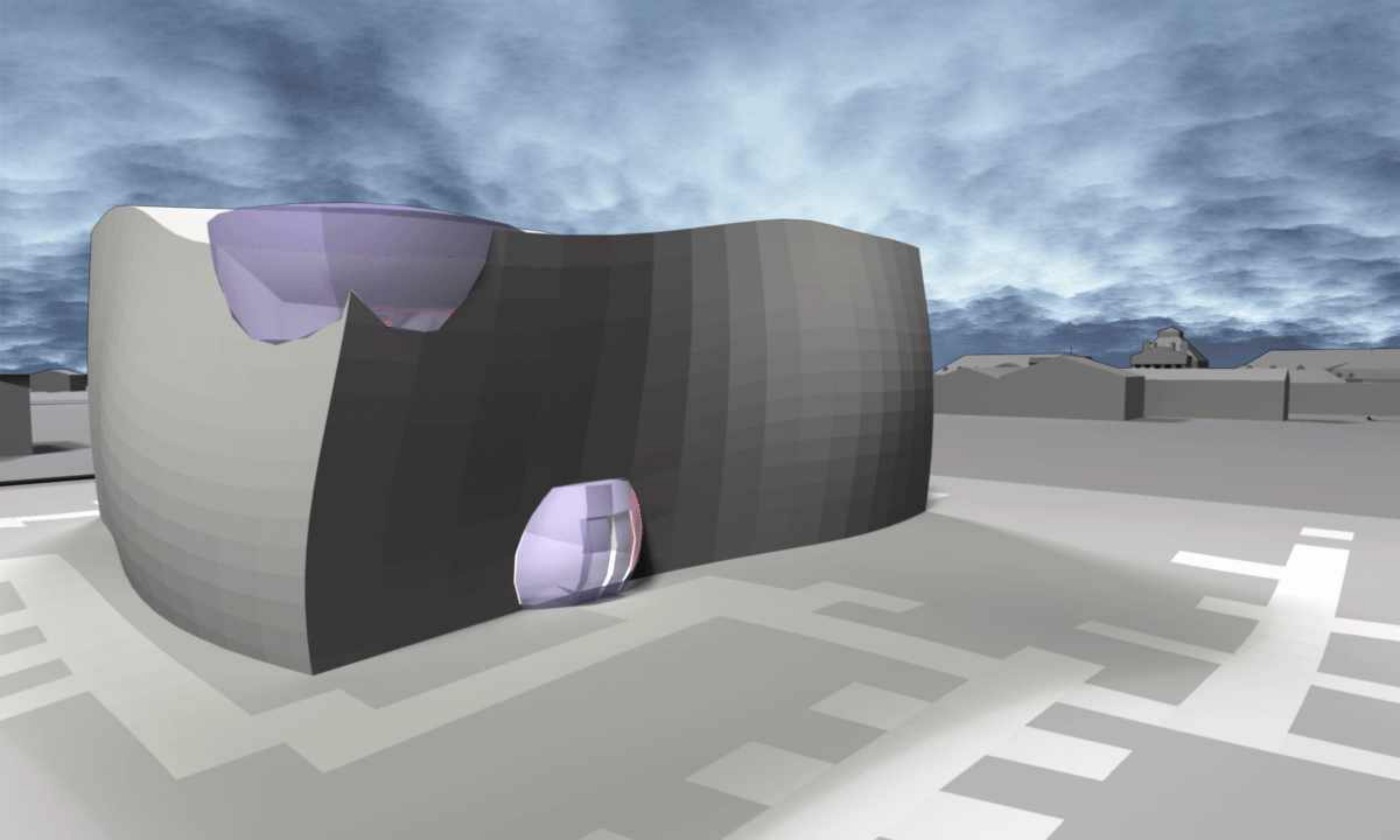



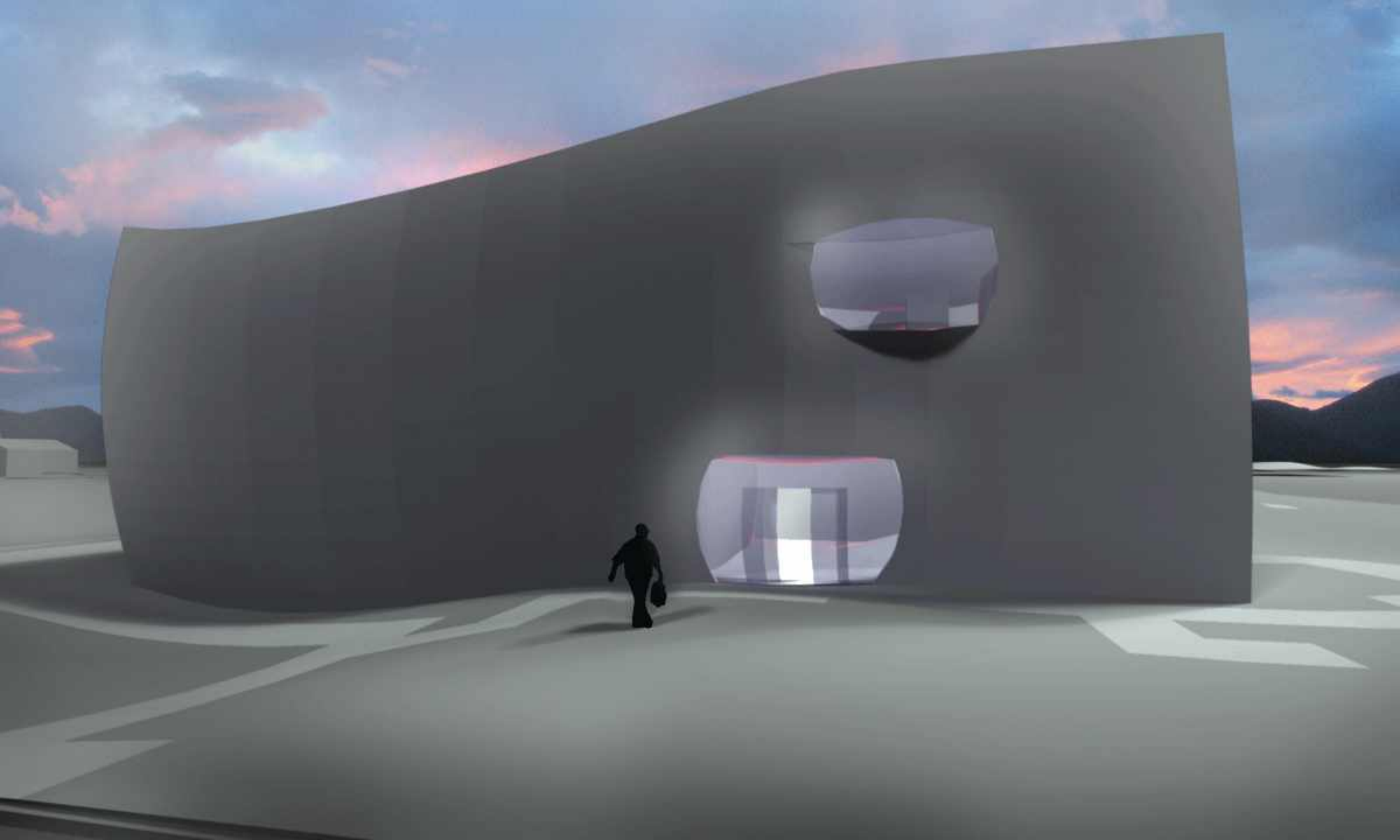



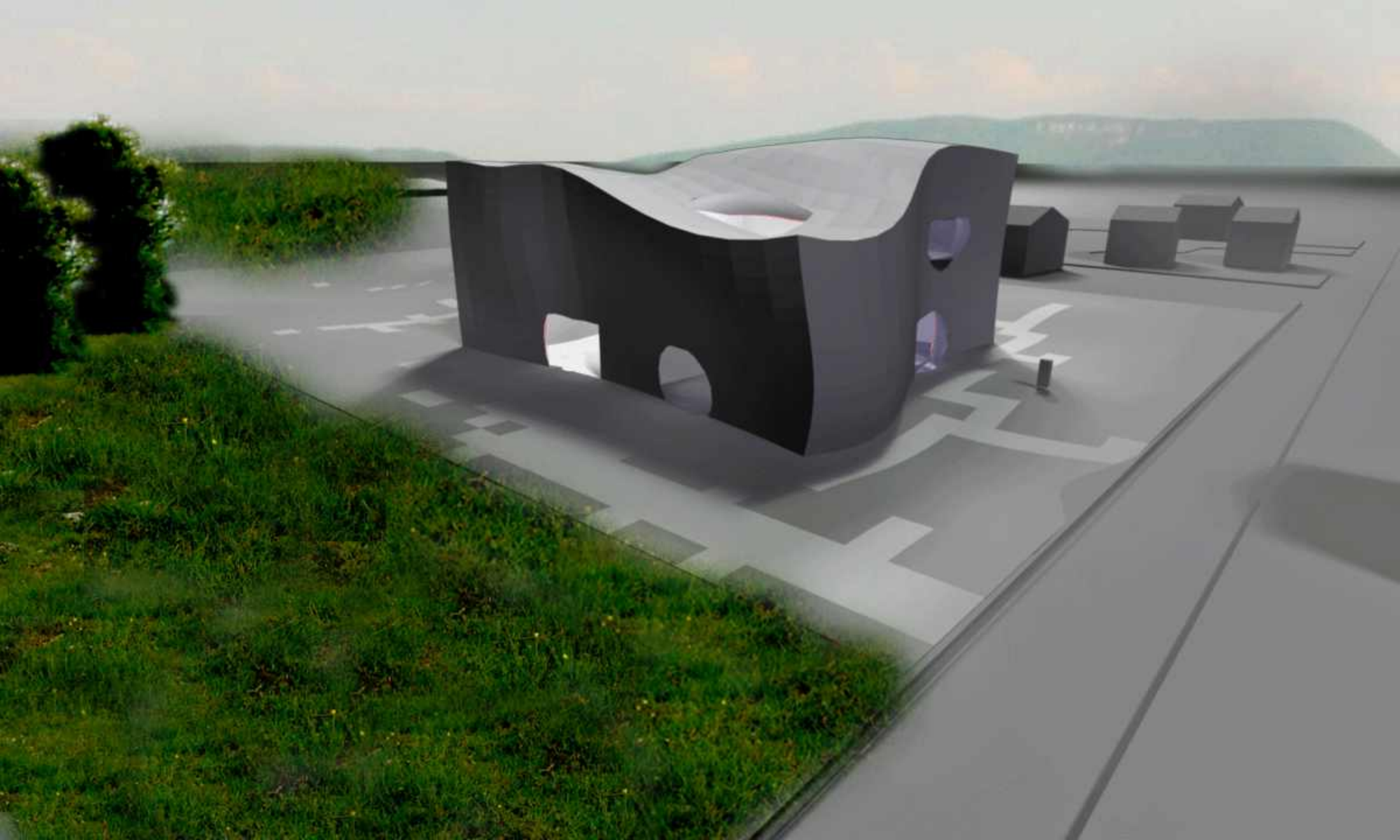



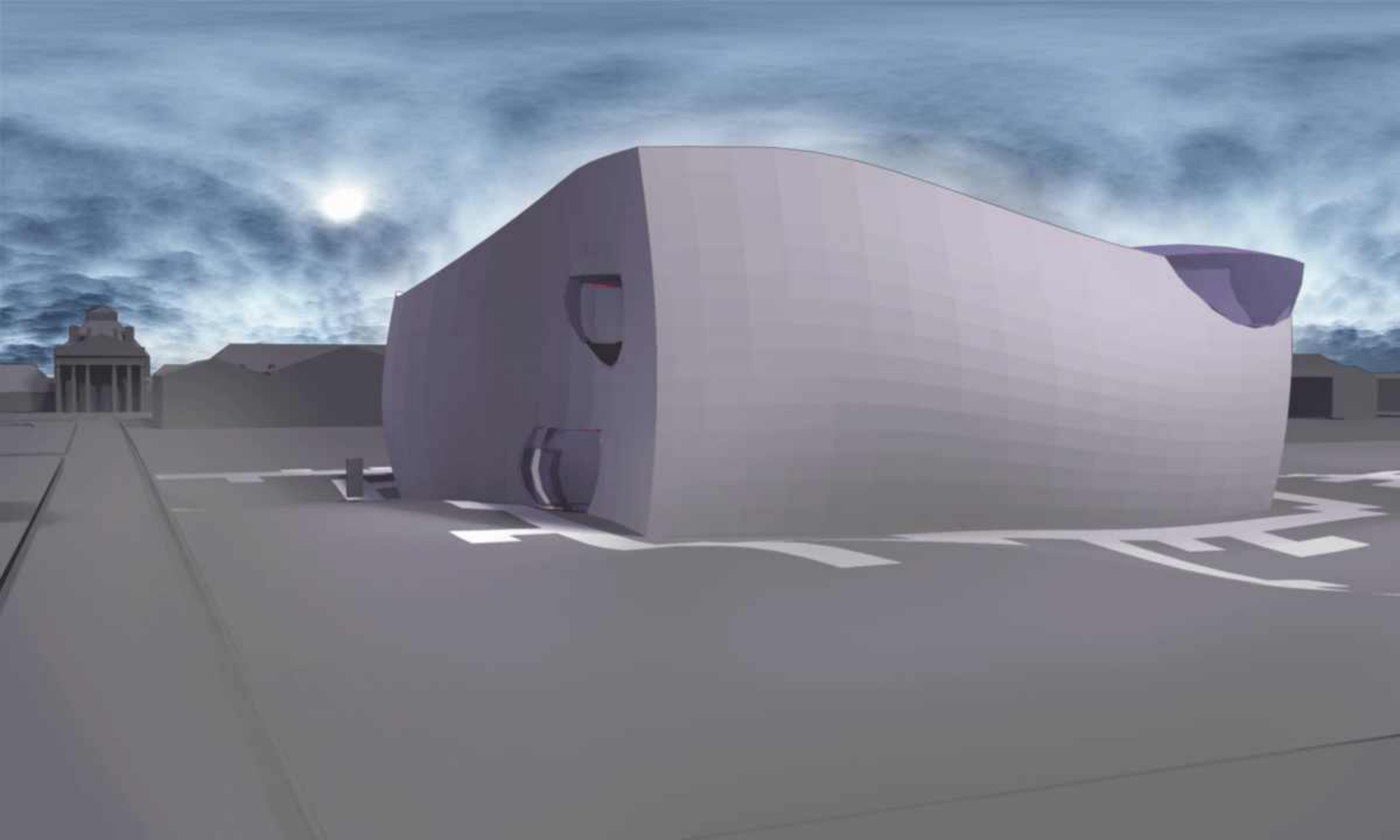





PHYSICAL MODEL 1:500 + SURROUNDING



JOSEPH STUDIO LYNN WS09  
**MASSIVE EFFECT**

**CHAMPIGNERIE** ARC-ET-SENANS



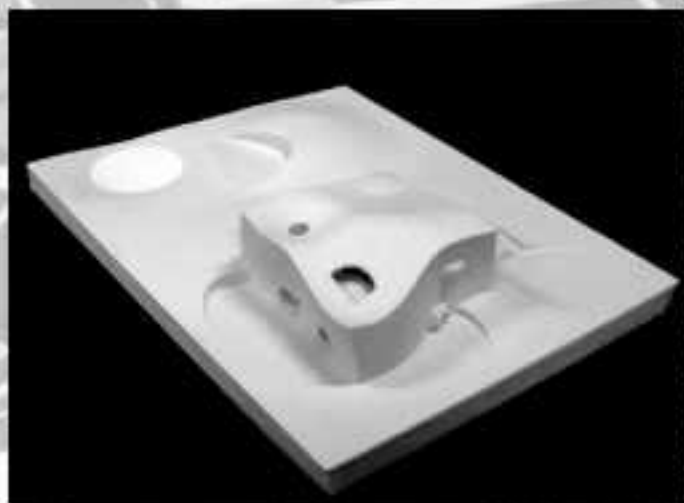

PHYSICAL MODEL 1:500 + SURROUNDING



JOSEPH STUDIO LYNN WS09  
MASSIVE EFFECT

CHAMPIGNERIE ARC-ET-SENANS



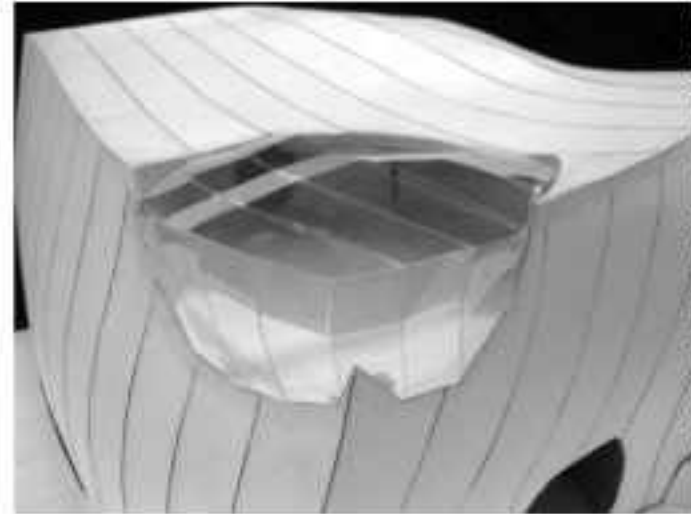
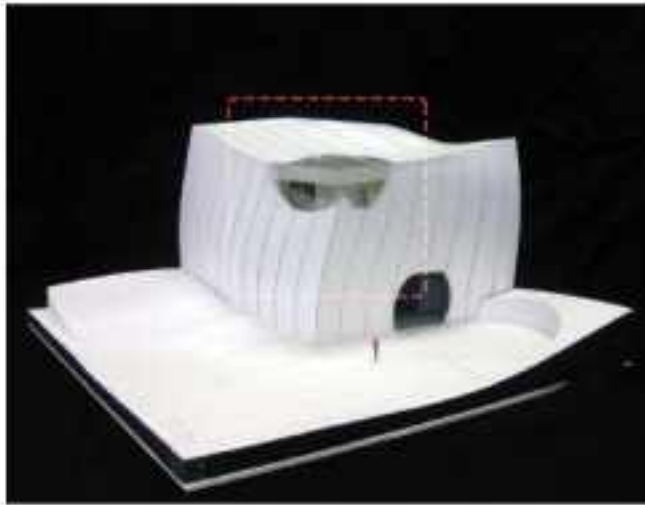

PHYSICAL MODEL 1:50 FINALS

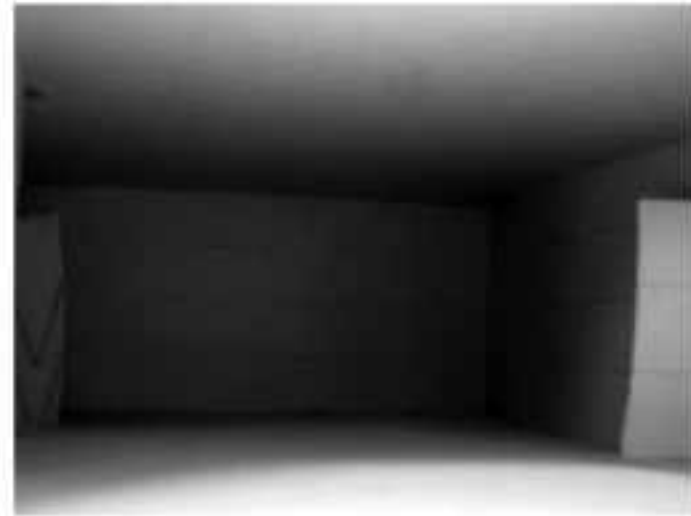

JOSEPH STUDIO LYNN WS09  
MASSIVE EFFECT

CHAMPIGNONERIE ARC-ET-SENANS





**PHYSICAL MODEL 1:50 FINALS**

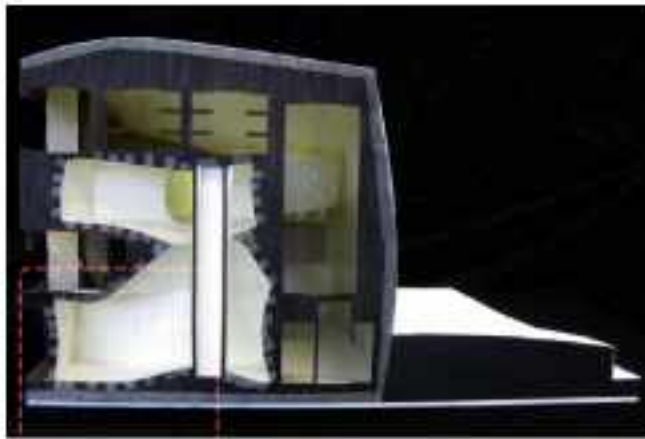



my **mass language** should be translated by punching bumps into an inertial material,  
 punching happens from outside as well as from inside,  
 so the **intersection between mass and void surface** results as aperture.

as mass physically is **inertial, mechanically deformed** iron (p.e.) feels massive  
 -> **the architecture is massive in expression.**  
 the **mass effect** is realized as **punched geometry.**

the problem of **poché** as the space between outside and inside is resolved by the **duality**  
 of stacking **quadroid spaces**/rooms into the **concavities and convexities** of the punched mass.





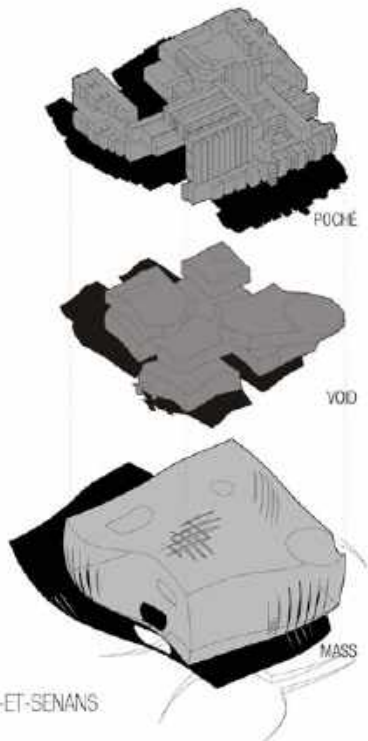

**MASS / VOID / POCHE RELATIONSHIP EXPLOSION DIAGRAM**



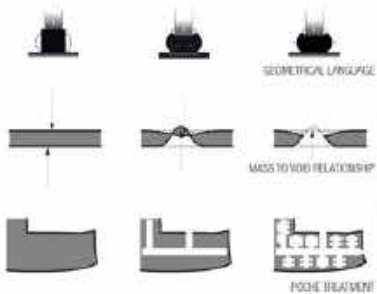

CONCEPTUAL DIAGRAMS



PHOTIE ARCHITECTS



AESTHETICAL REFERENCES



**CHAMPIGNONERIE** ARC-ET-SENANS



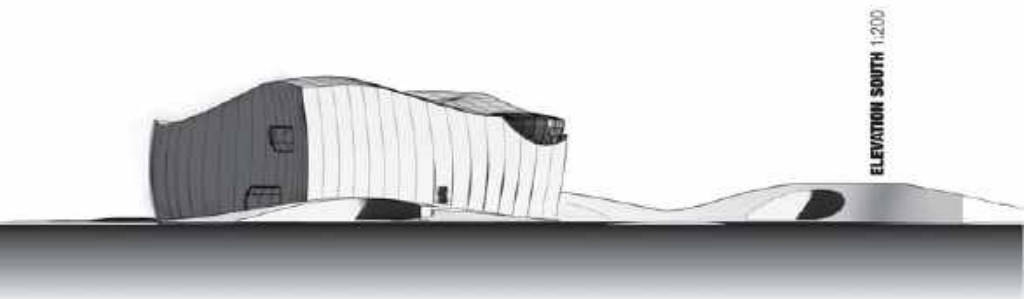

ELEVATION SOUTH 1:200



SECTION A-A 1:200



JOSEPH STUDIO ENN WSOB  
**MASSIVE EFFECT**

**CHAMPIGNONERIE** ARC-ET-SENANS



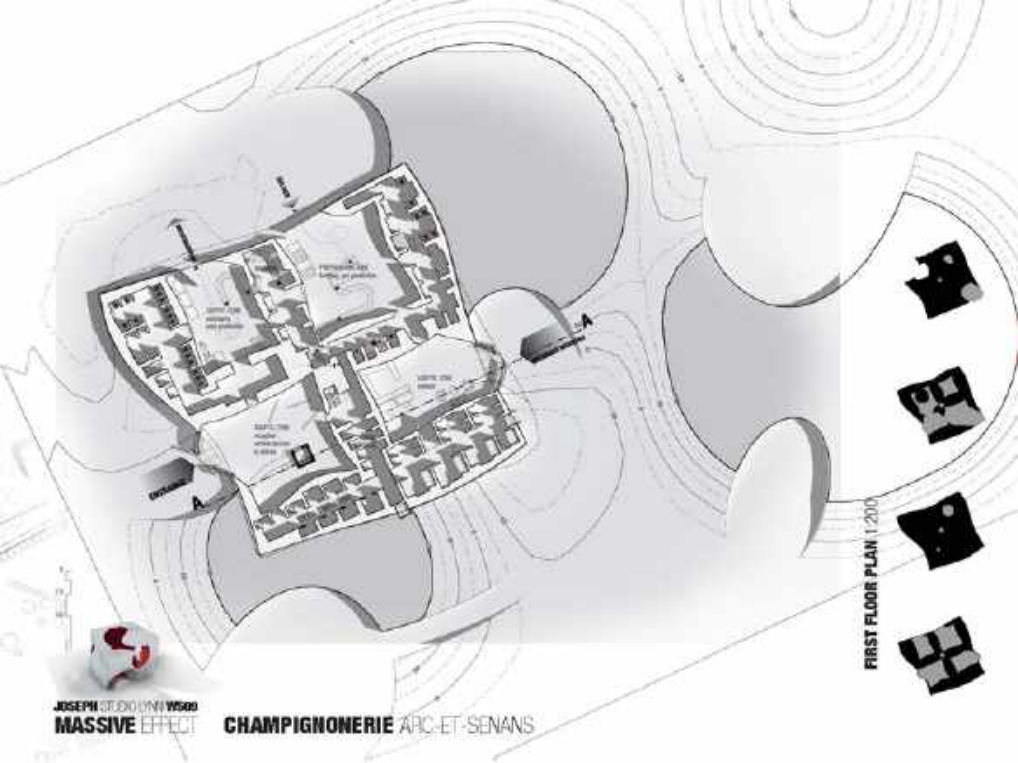

JOSEPH STUDIO UNIVISKO  
**MASSIVE EFFECT**

**CHAMPIGNERIE ARC-ET-SENANS**

FIRST FLOOR PLAN 1:200







SITEPLAN 1:1000



JOSEPH STUDIO  
**MASSIVE EFFECT**

**CHAMPIGNERIE** ARC-ET-SENANS





MASSIVE EFFECT



MASS BACKWARD



JOSEPH STUDIO  
MASSIVE EFFECT

CHAMPIGNERIE ARC-ET-SENANS



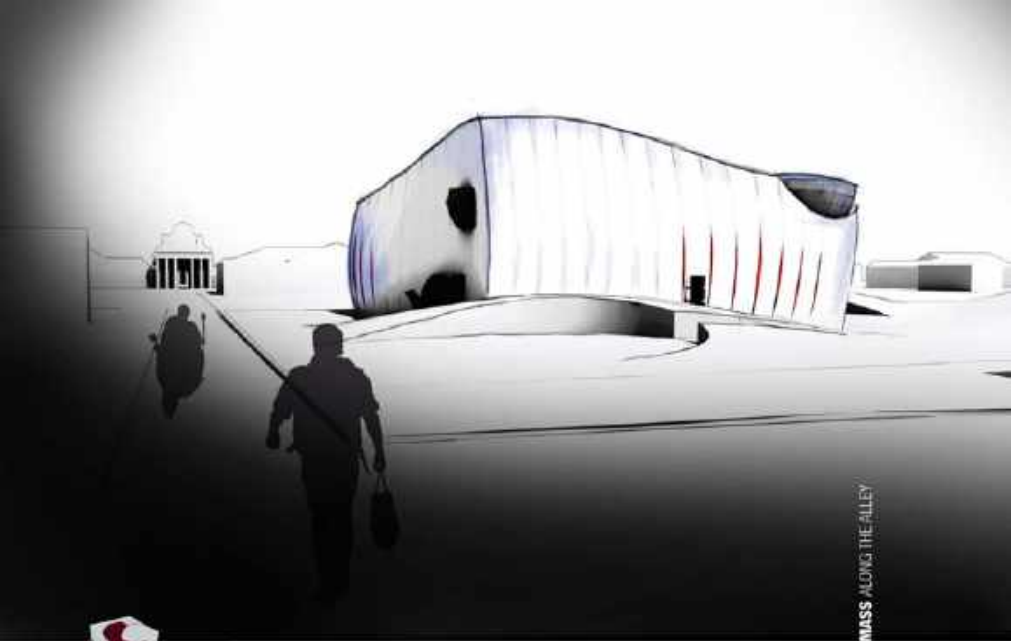

MASS ALONG THE ALLEY



JOSEPH STUDIO WITH WSOO  
**MASSIVE EFFECT**

**CHAMPIGNERIE** ARC-ET-SENANS



# **SONSTIGE PROJEKTE**



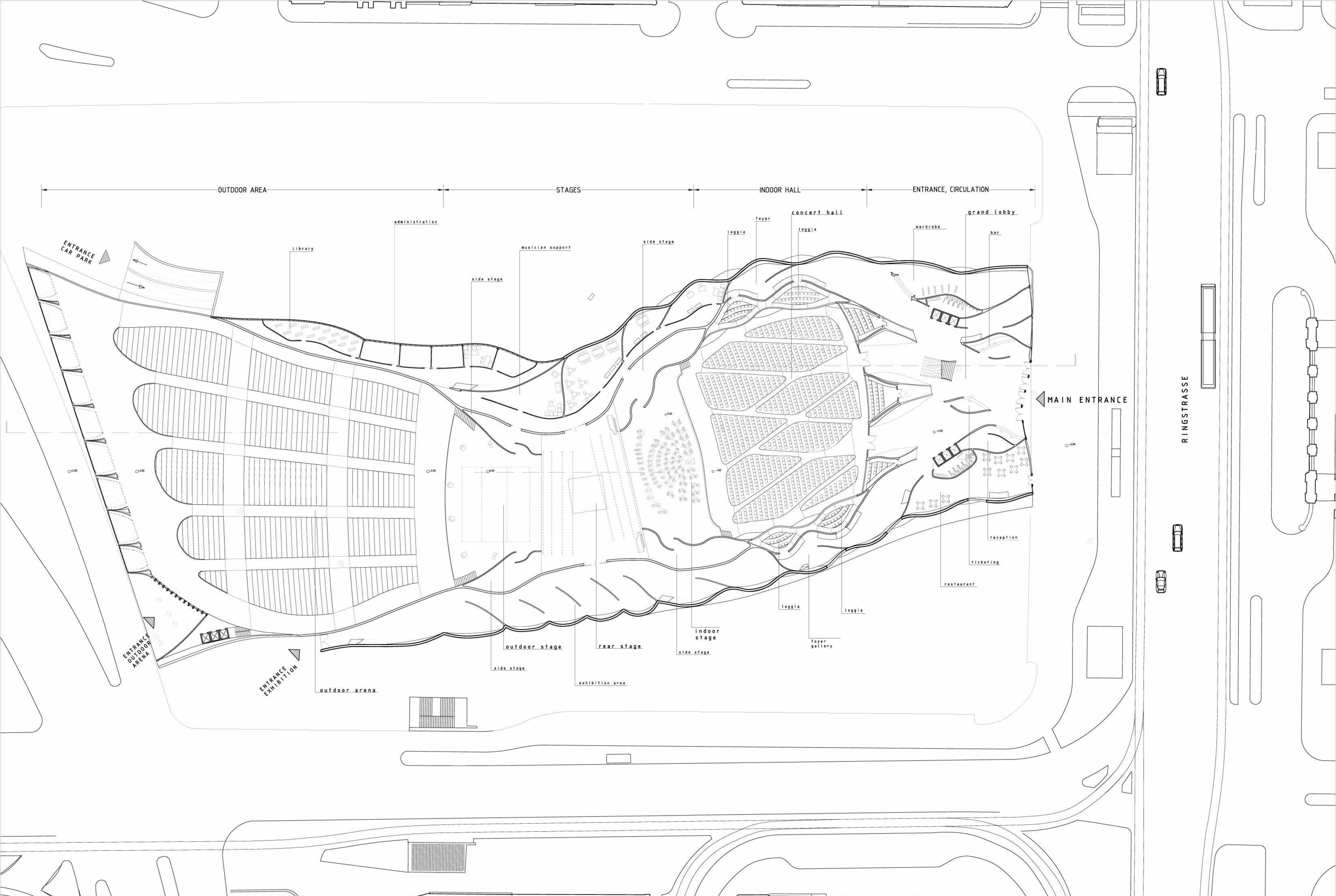



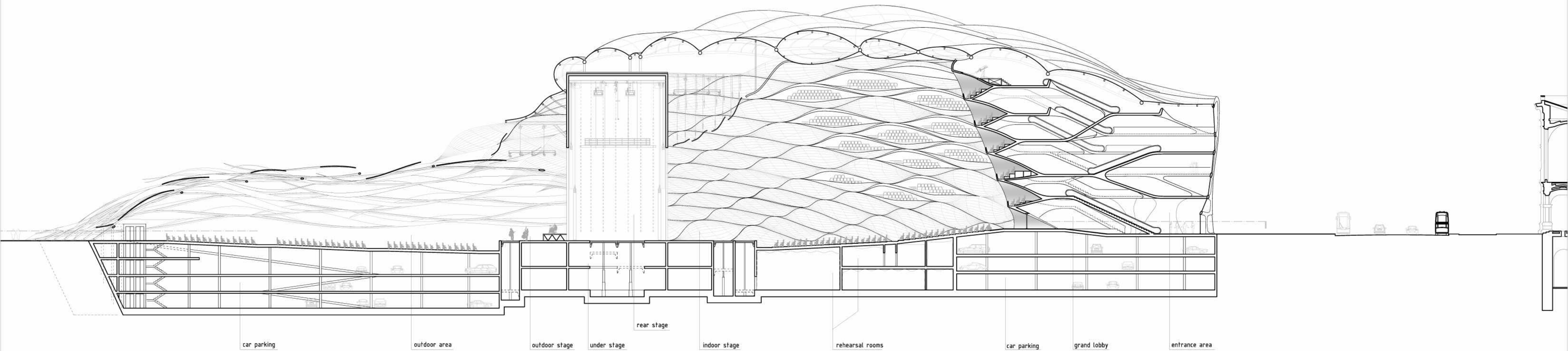



















main grid reshaping

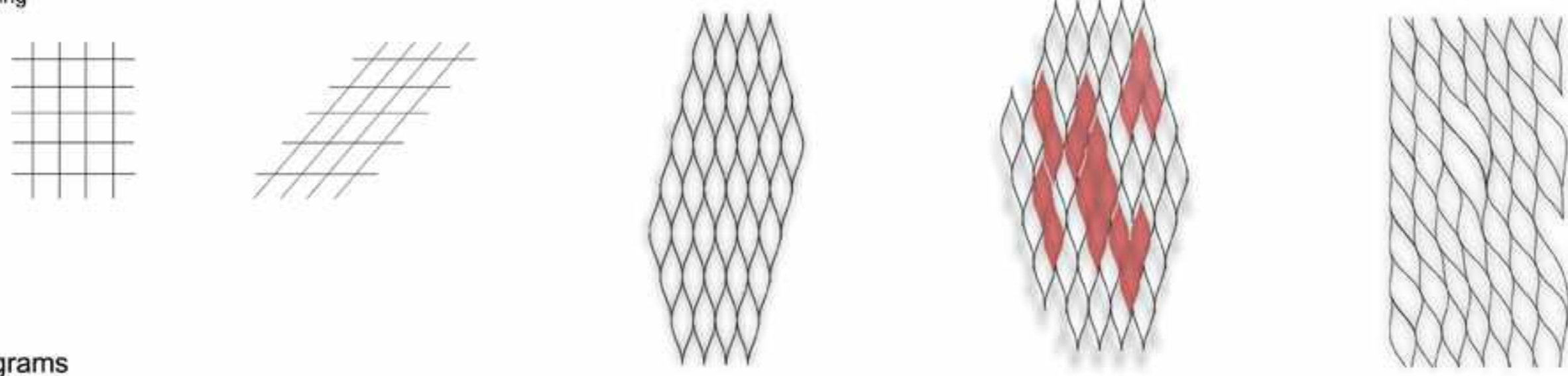

massing diagrams

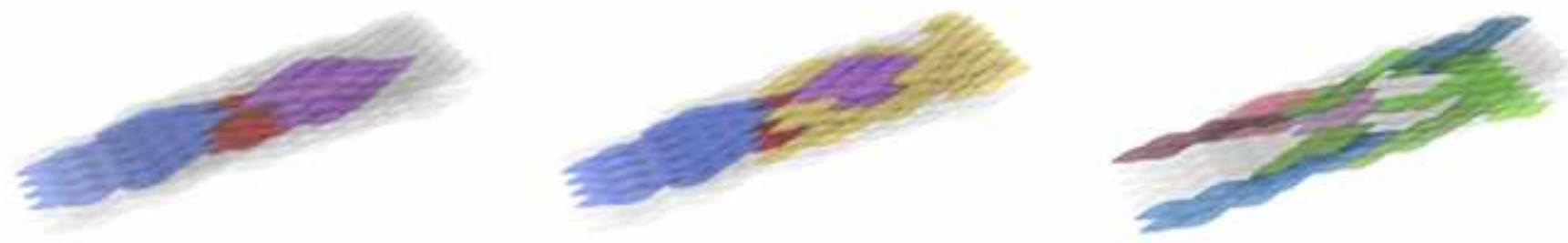

moduls conections



outside hall approach



outdoorhall

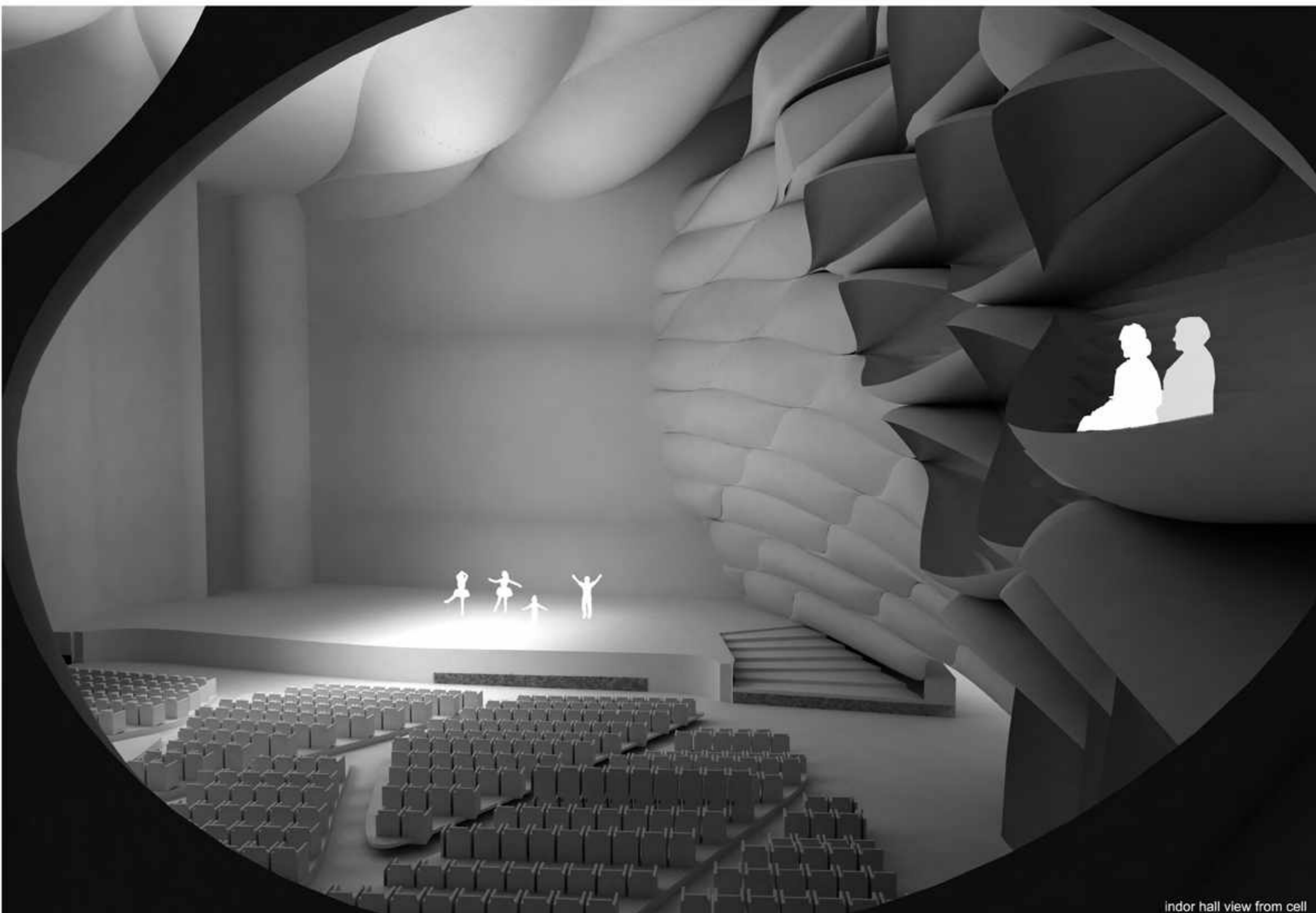

indor hall view from cell

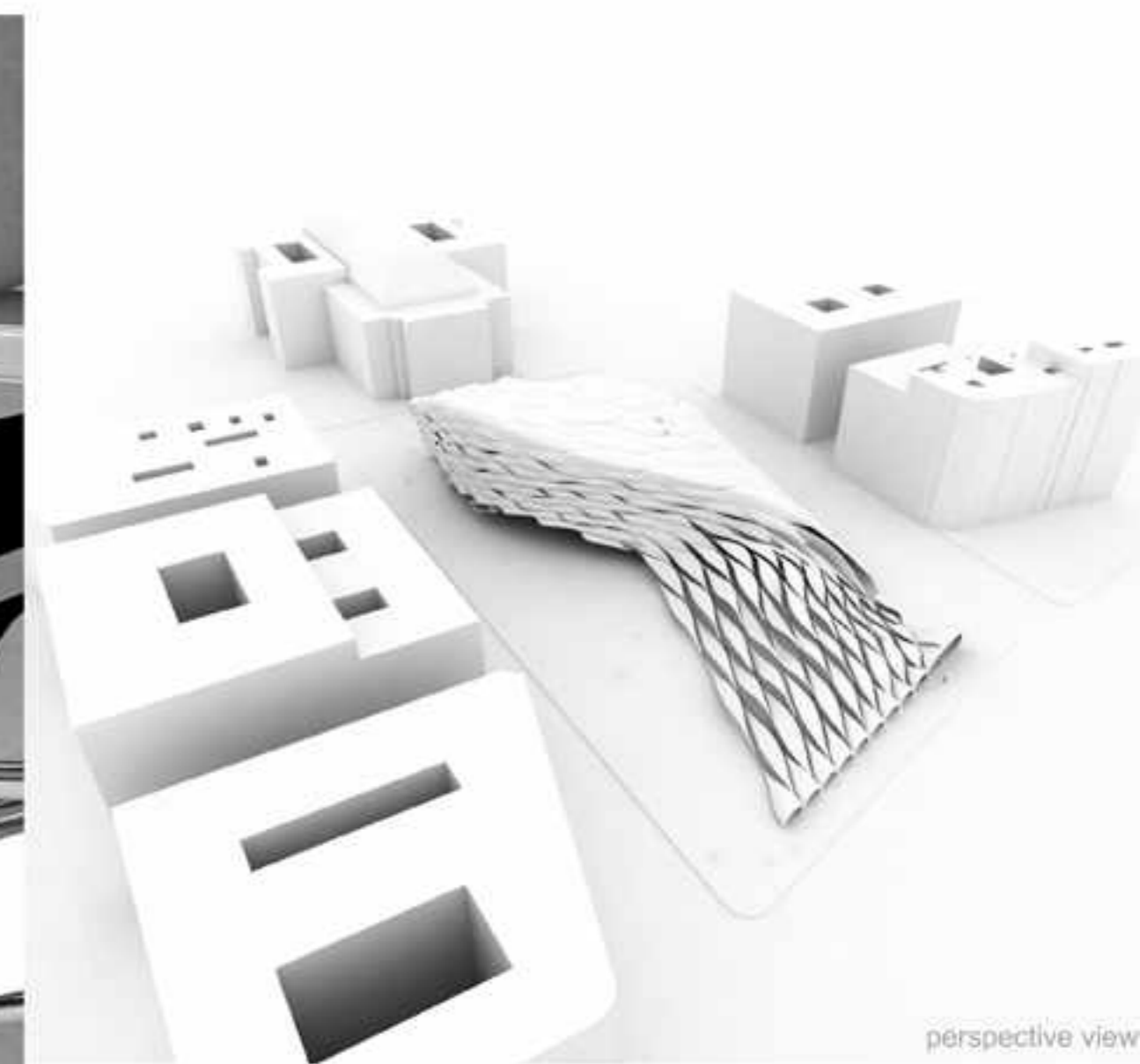
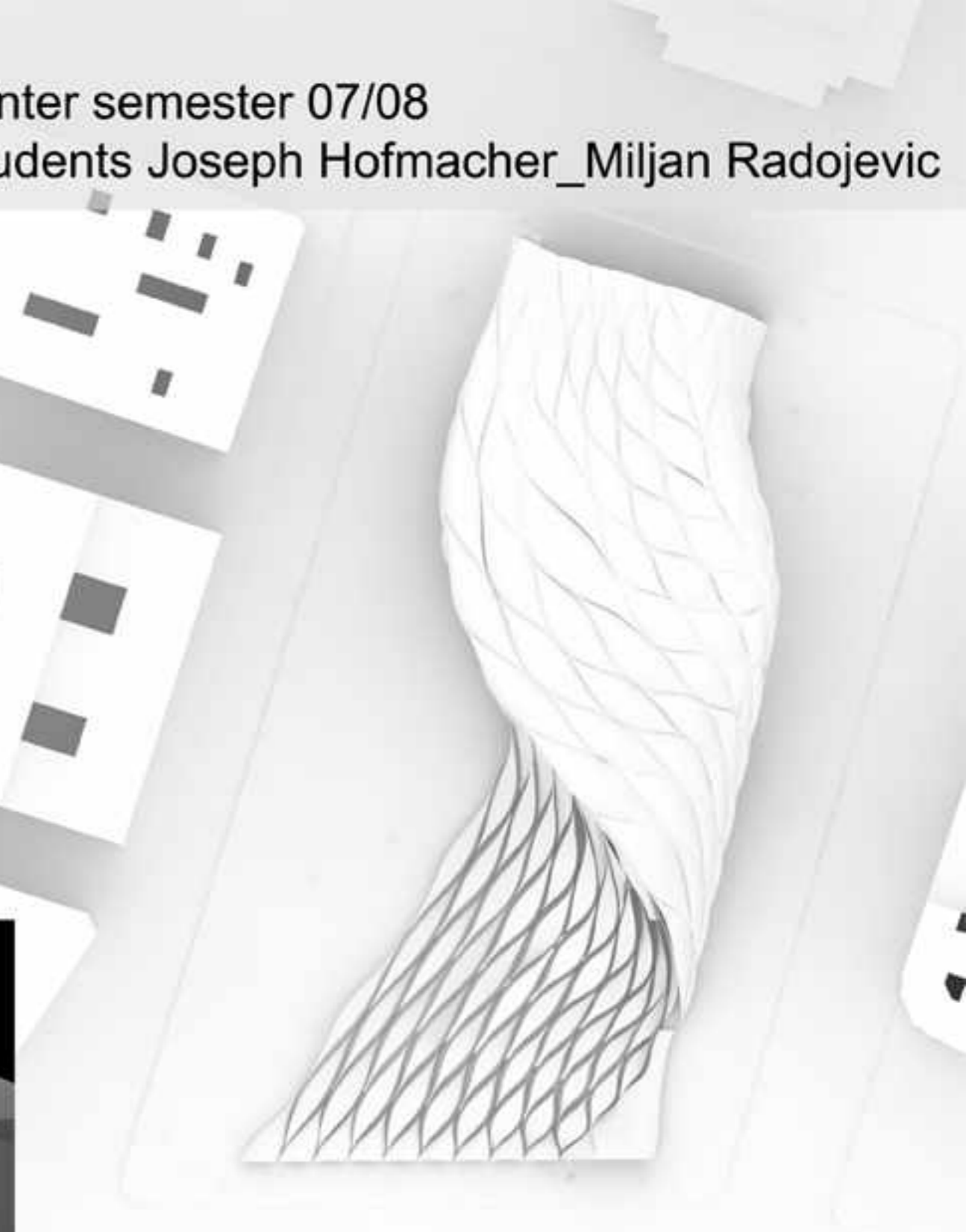

perspective view



moduls design details





# TRANSFORMING THE NEUE NATIONALGALERIE

Lisa Höck &  
Joseph Hofmarcher

STUDIO LYNN  
di:Angewandte  
Summer 2010

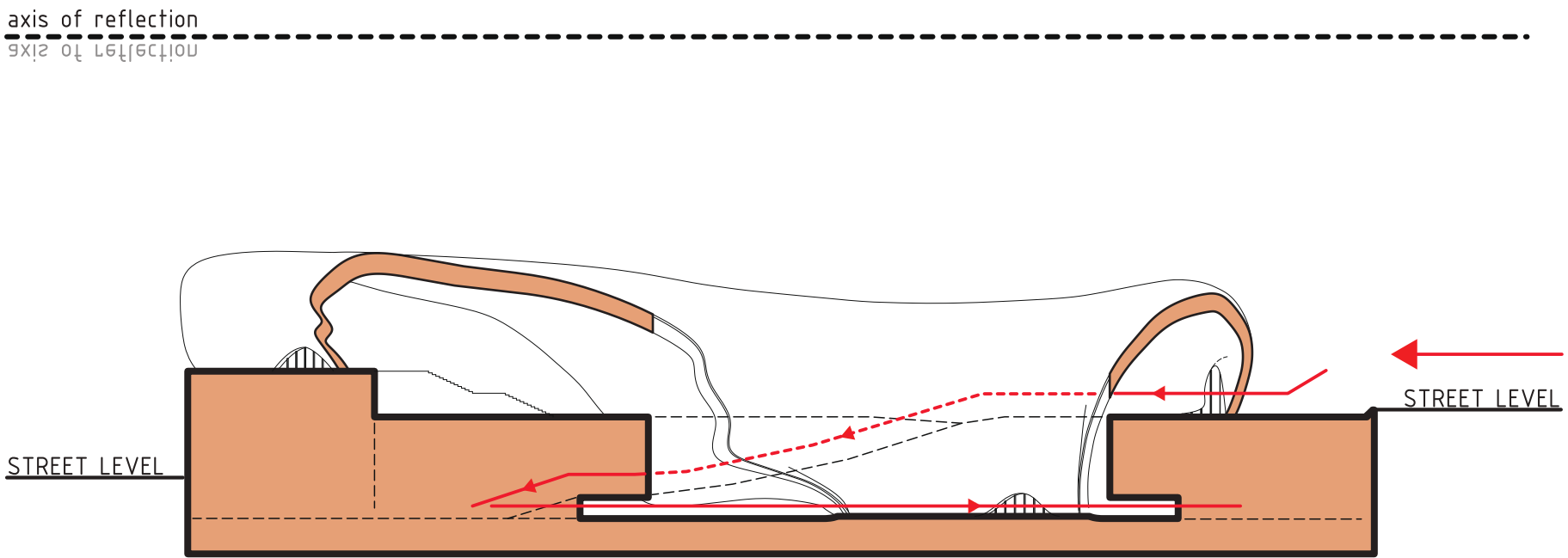

## MIES UPSIDE DOWN

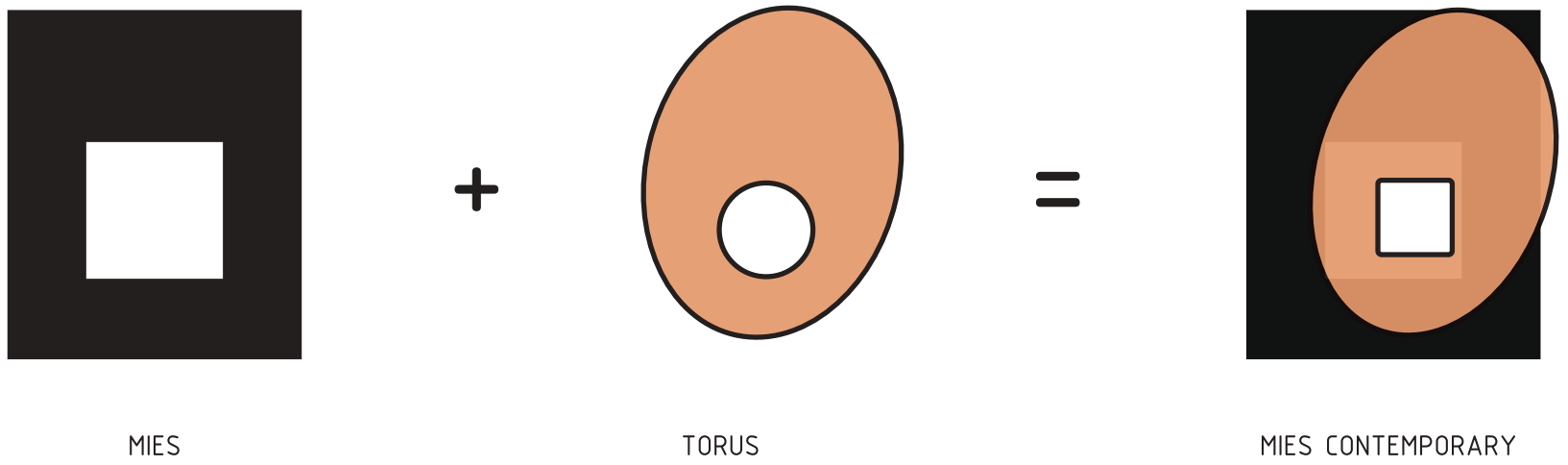

## 2 BIG SHAPES

## DIAGRAMS





HIDDEN LINE PERSPECTIVE



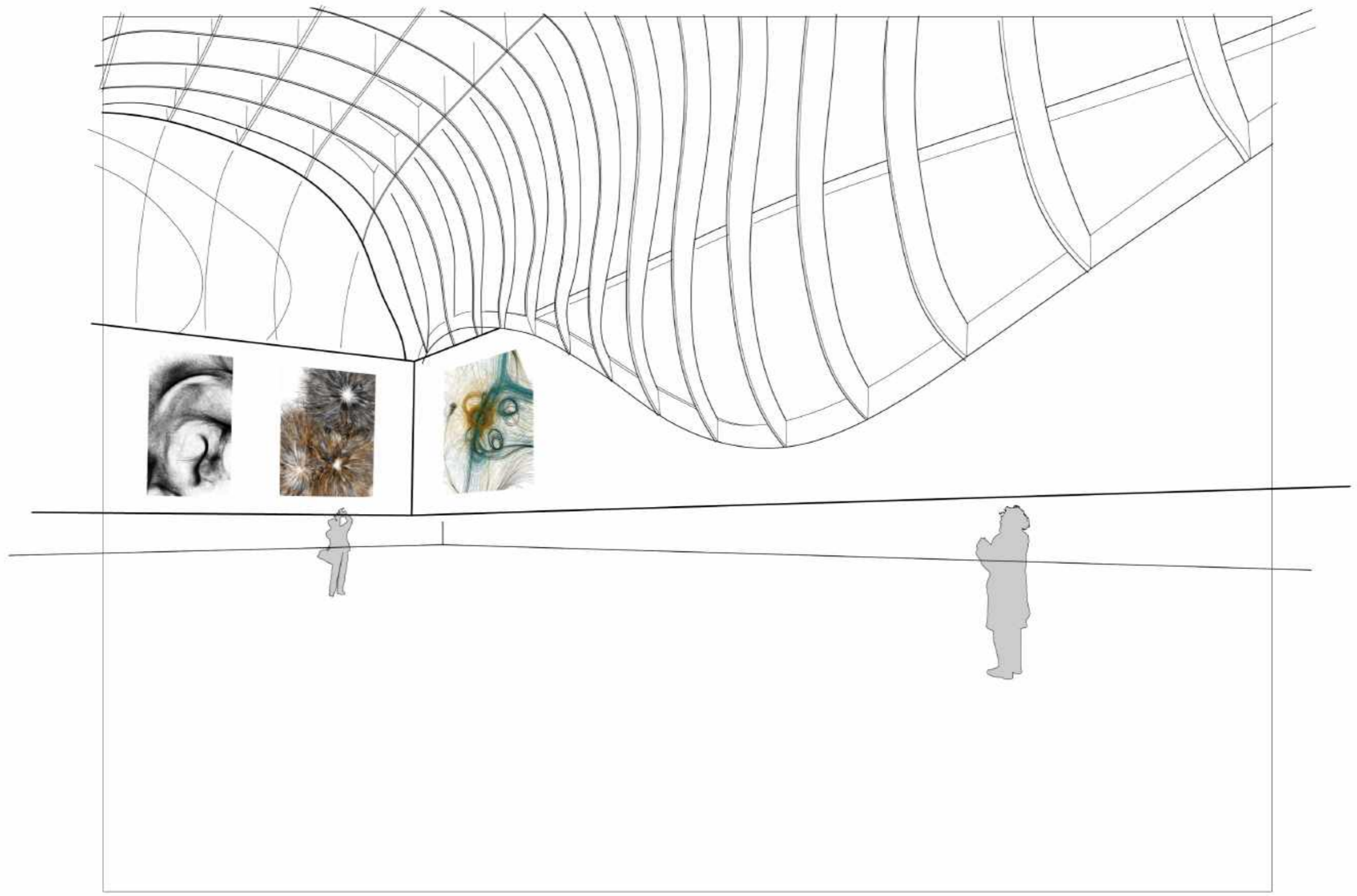



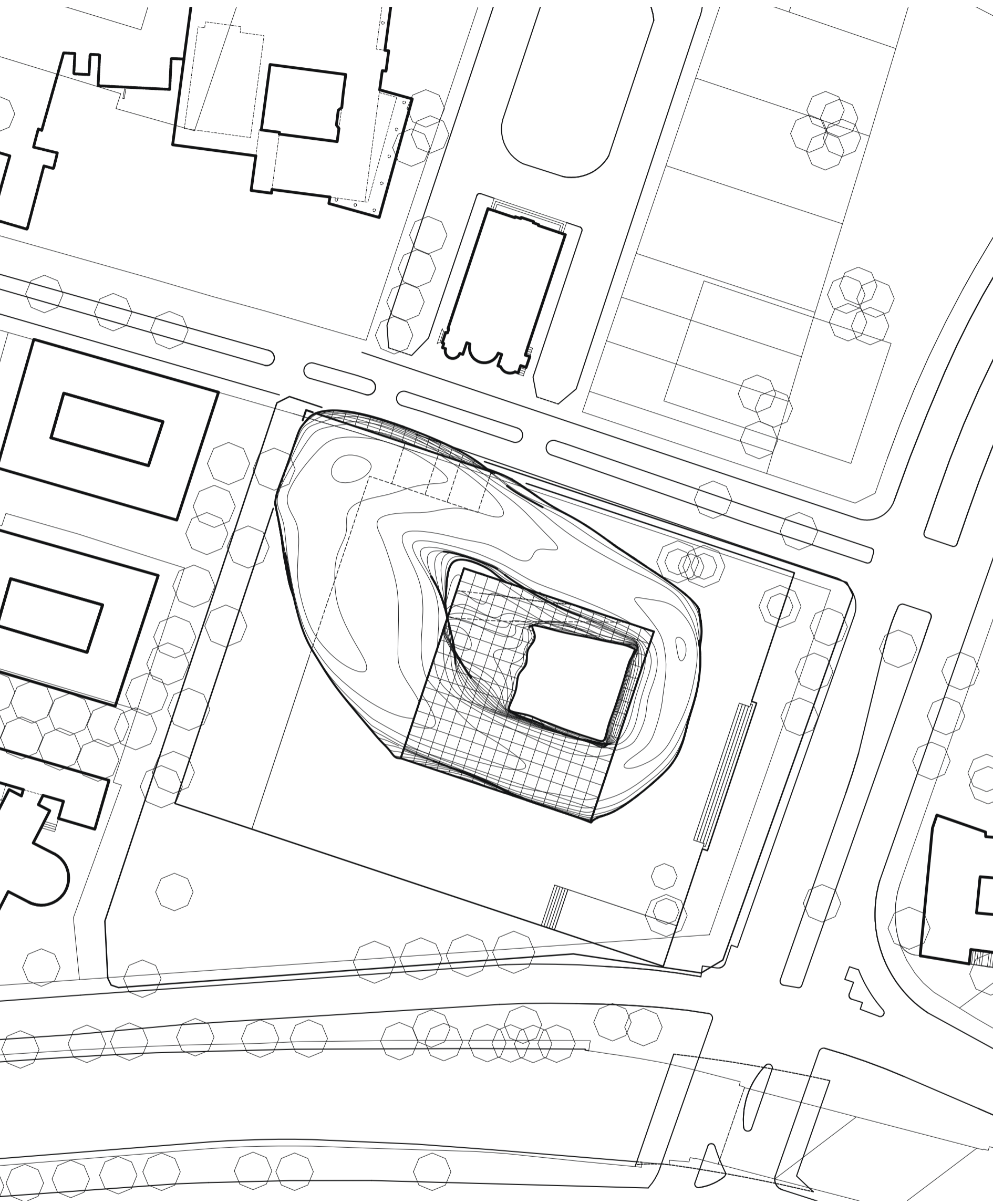

*SITEPLAN 1:1000*

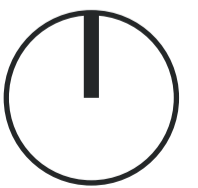



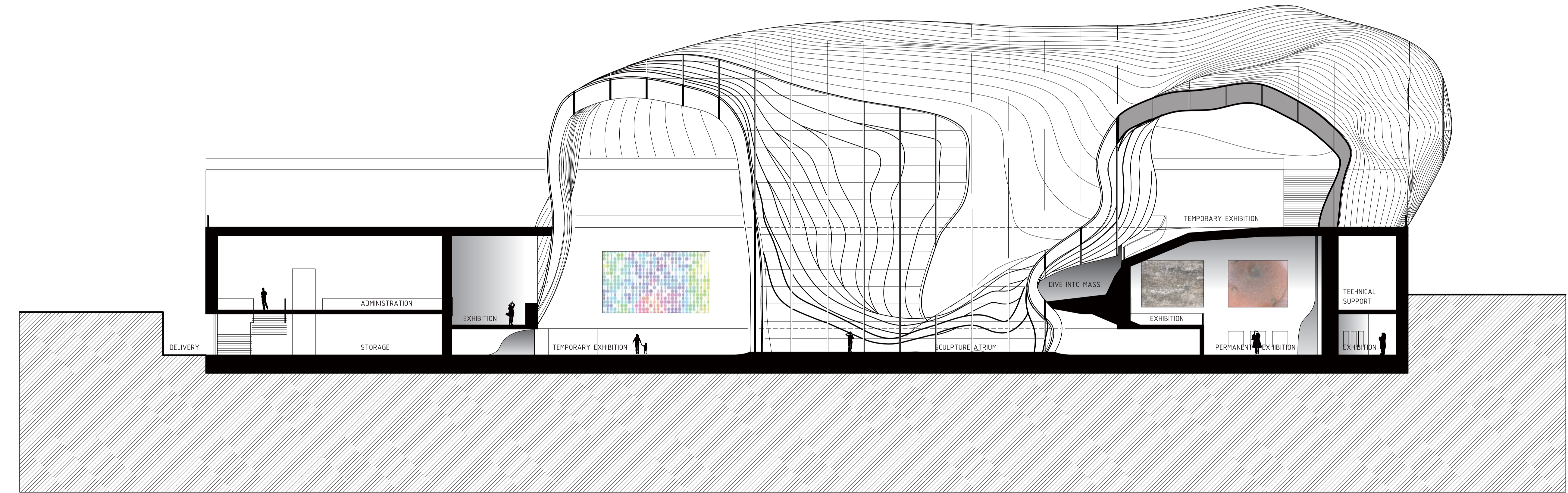
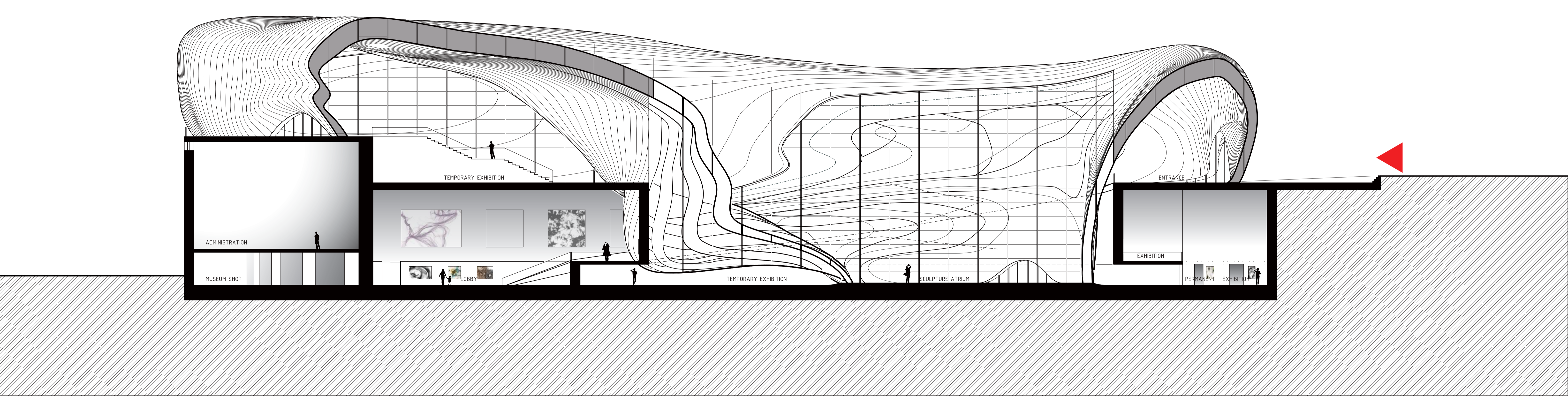

SECTION A-A 1:200

SECTION B-B 1:200



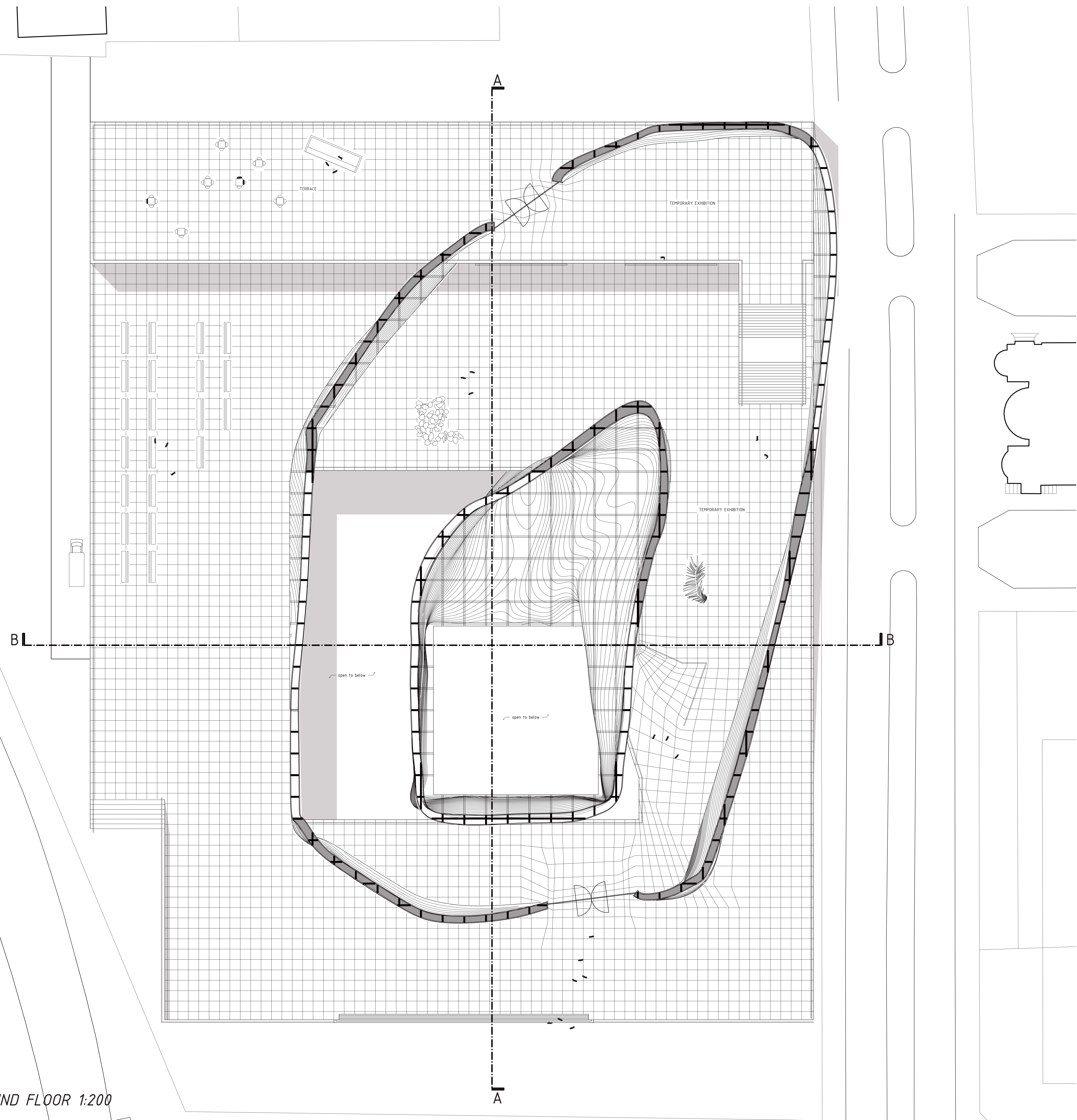

GROUND FLOOR 1:200

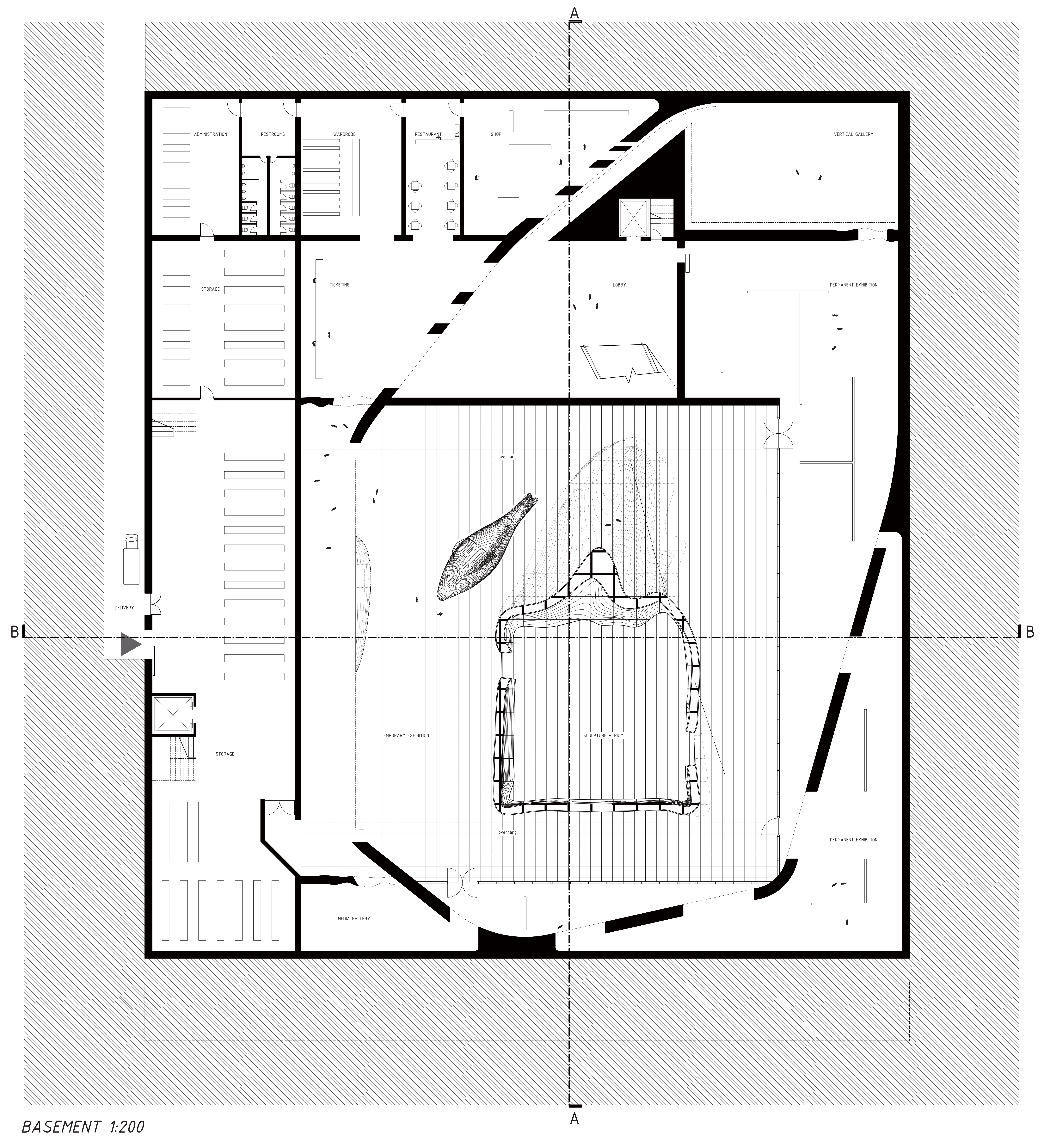

BASEMENT 1:200











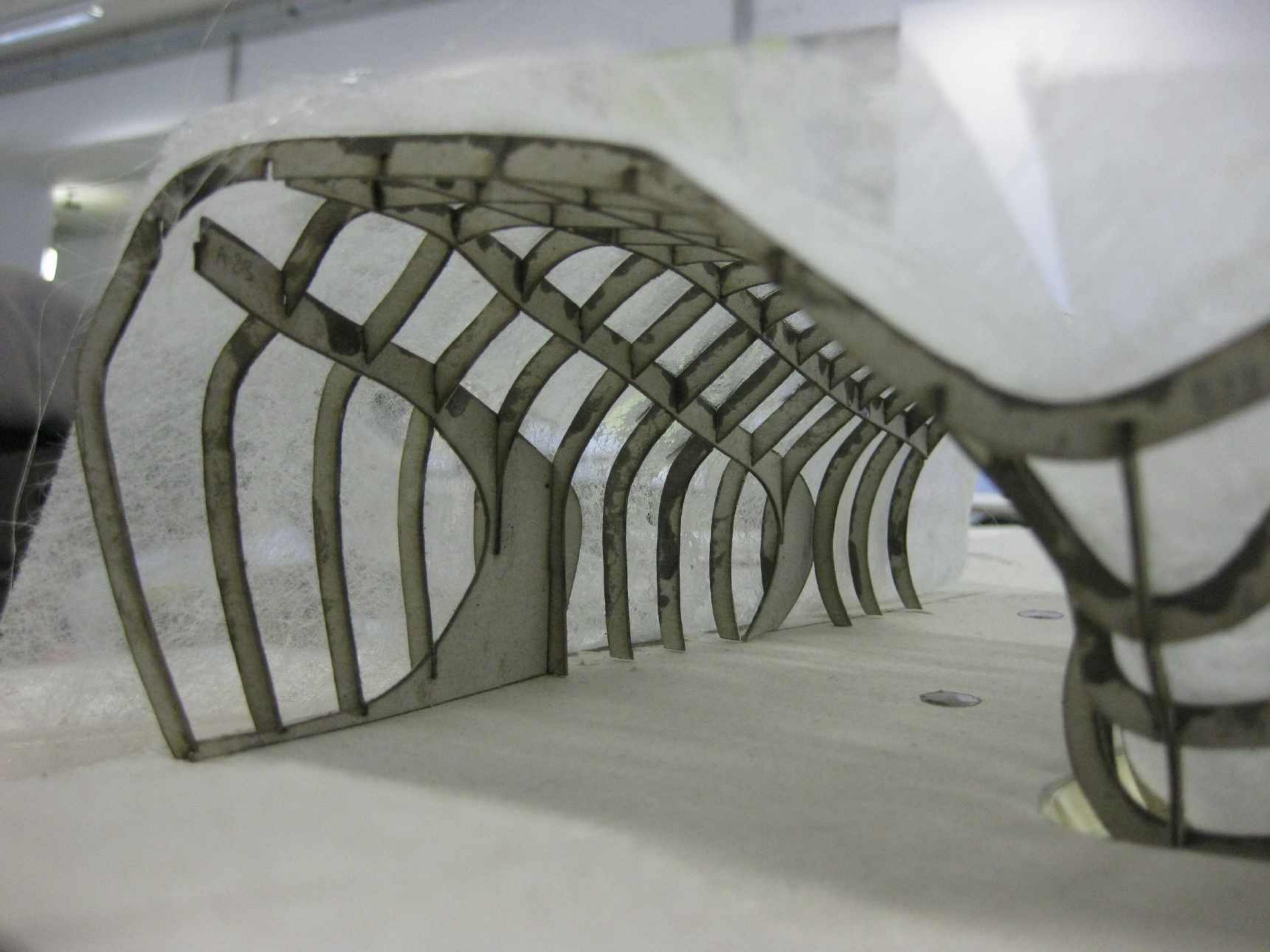







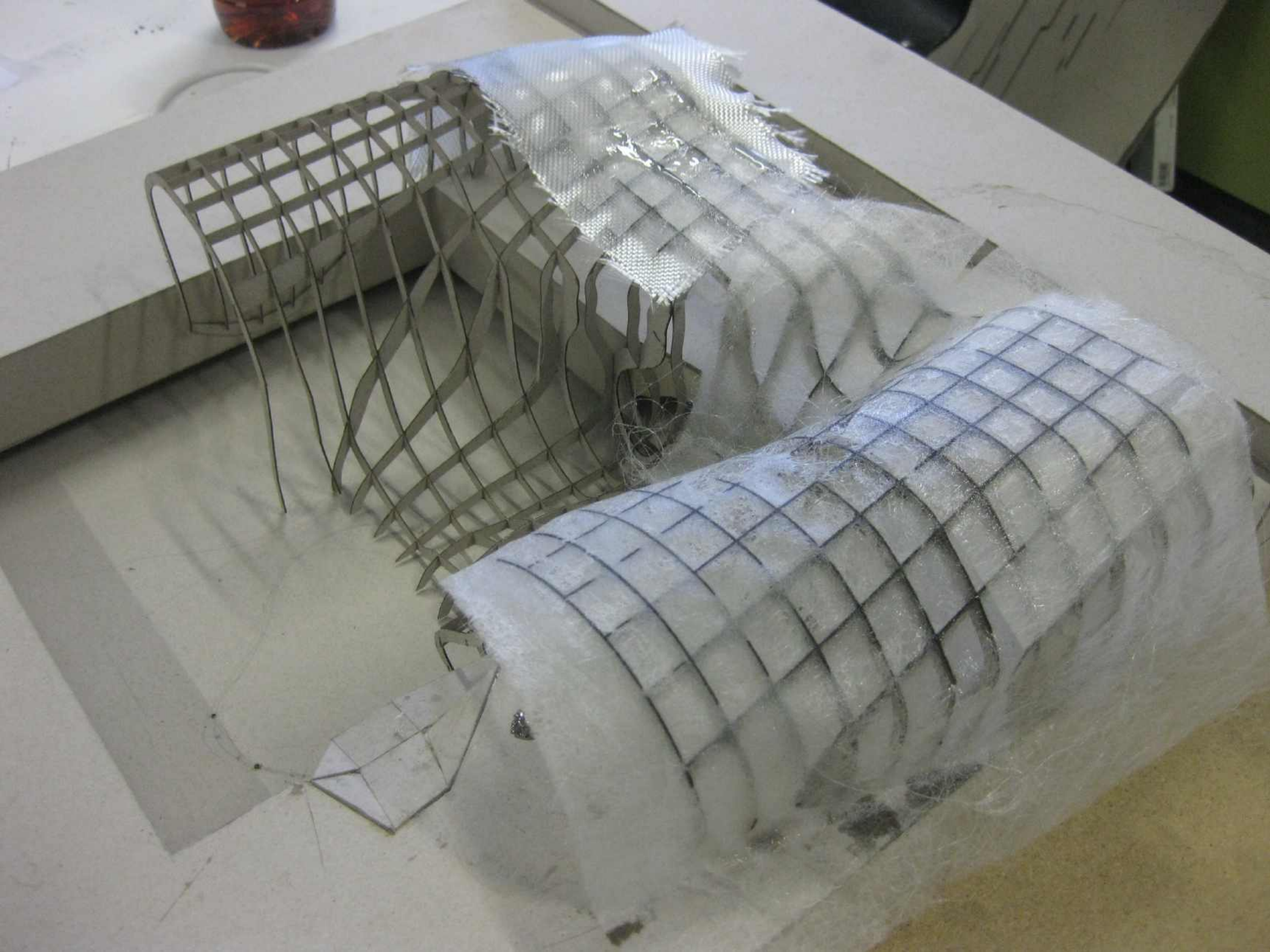



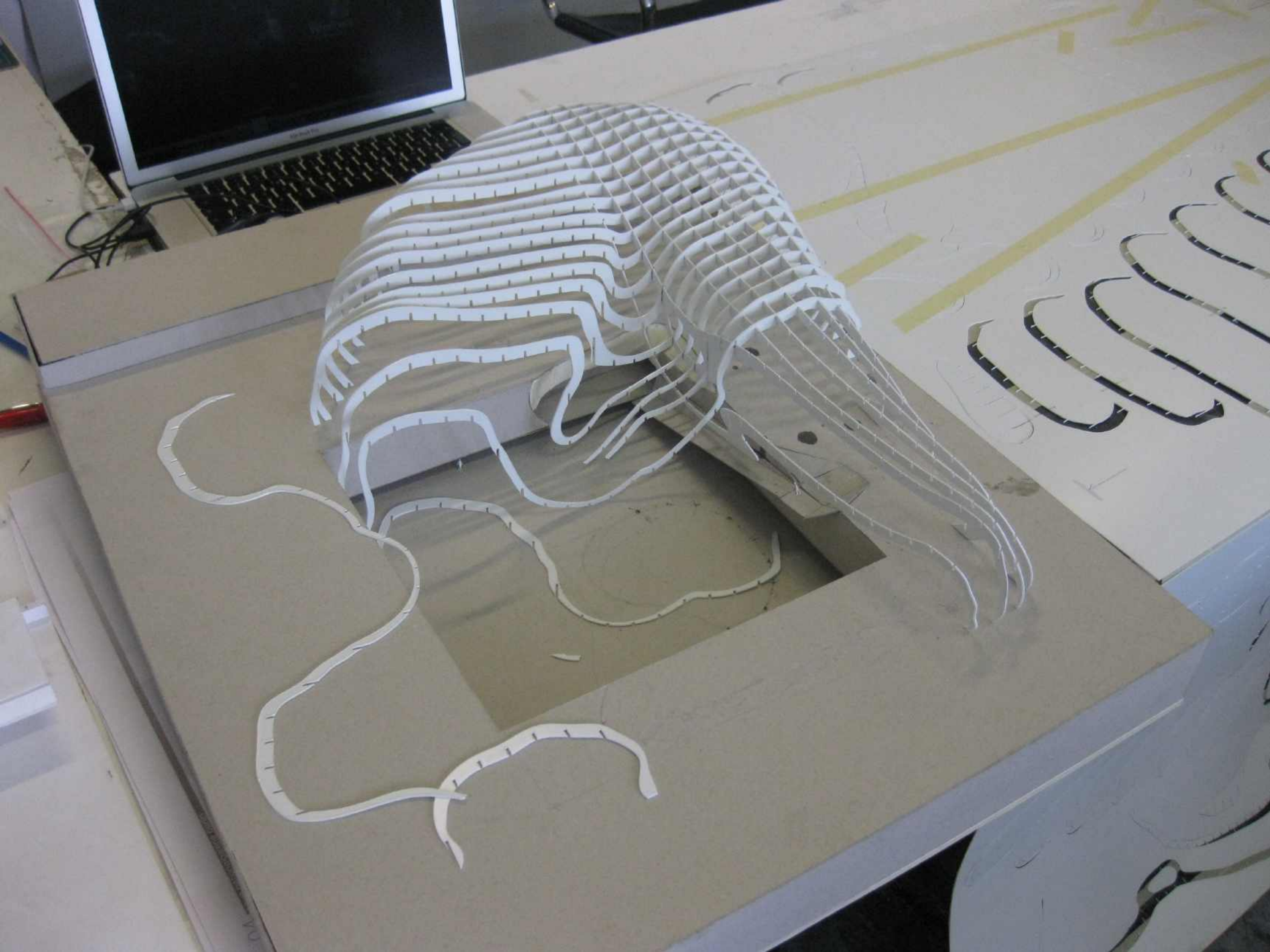





HIDDEN LINE PERSPECTIVE



**DANKE FÜR DIE  
AUFMERKSAMKEIT**